

KOSO HAMMEL DAHL

CONTROL VALVES

KOSO HAMMEL DAHL
253 Pleasant Street
West Bridgewater, MA 02379

tel: 774.517.5300
fax: 774.517.5230
www.hammeldahl.com

Installation, Maintenance & Operating Instructions

IMO - A46 - 2

PNEUMATIC DIAPHRAGM TYPE A46 DIRECT ACTUATOR

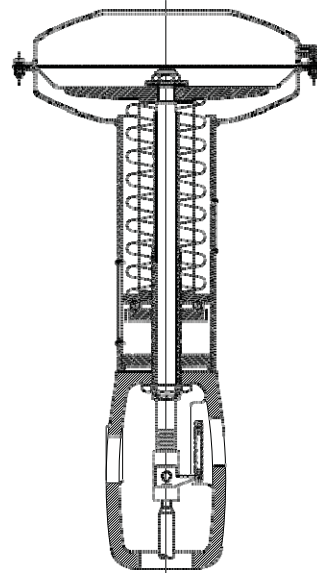

Read these instructions carefully before installation or servicing.

WARNING !

FOR YOUR SAFETY AND PROTECTION, IT IS IMPORTANT THAT THE FOLLOWING PRE-CAUTIONS BE TAKEN PRIOR TO REMOVAL OF THE UNIT FROM THE LINE OR BEFORE ANY DISASSEMBLY:

1. DO NOT at any time place your hand in the valve port when the units are assembled together. A remotely actuated valve could close at any time and result in serious injury.
2. Know what media is in the line. If there is any doubt, check with the proper authority.
3. Wear any protective clothing or equipment normally required when working with the fluid involved during removal and disassembly
4. Shut off the service pressure and bleed the service lines before removing the service line connectors from the actuator.
5. If the valve/actuator assembly is removed from the line as a unit, make sure both upstream and downstream sides of the line are depressurized before removal. Refer to valve IMO for more instructions
6. Ensure that the spring is decompressed before disassembly.

TABLE OF CONTENTS

Description.....	3
Disassembly.....	3
Diaphragm Removal	3
Complete Disassembly	3
Assembly.....	3
Preliminary Assembly.....	3
Final Assembly.....	3
Adjustments.....	4
Adjusting Actuator Stroke.....	4
Setting the Inherent Diaphragm Pressure Range	4
Setting the Installed Diaphragm Pressure Range	4
<i>Figure 1</i>	5
<i>Table 1</i>	5
<i>Figure 2</i>	6
<i>Table 2</i>	6

These instructions are subject to change without notice.

DESCRIPTION

In the “normal” position (no air pressure on diaphragm) the Direct Actuator holds its stem in a fully retracted position by means of the spring. Increasing air pressure in the upper diaphragm chamber thrusts the actuator stem downward and compresses the spring. Decreasing air pressure allows the spring to return the stem to its normal position.

1. Mounted on Pull-Stem-to-Open valve body assemblies, the Direct Actuator closes the valve upon increasing air pressure to the upper diaphragm chamber.
2. Mounted on Push-Stem-to-Open valves, the Direct Actuator opens the valve upon decreasing air pressure to the upper diaphragm chamber.

Raised mounting pads on the actuator yoke casting accommodate accessories such as positioner, controller, solenoid valves, limit switches, etc. To facilitate disassembly, all accessories should be removed before proceeding as outlined below.

DISASSEMBLY

Remove the actuator from the valve body assembly.

CAUTION: Do not remove diaphragm cap screws without relieving spring compression.

Diaphragm Removal

1. Remove the dust cap (16) from the spring barrel case assembly (21).
2. Relieve all spring compression by inserting a screwdriver through the dust cap slot and rotating the spring adjuster (11) counterclockwise.
3. Remove the cap screws and nuts (9 & 10), then lift off the diaphragm case (1).
4. Loosen the travel stop nut set screw (19), and unscrew the travel stop nut (3) from the actuator stem.
5. Withdraw the actuator stem assembly from the spring adjuster screw (32), and remove the upper travel stop (30).
6. Unscrew the actuator stem nut (17) to free the diaphragm washer (18) and diaphragm (15) from actuator stem (20).

Note: For reassembly after replacement of the diaphragm only, refer to section “Final Assembly,” section 8.b.

Complete Disassembly

7. Remove the spring (29) and spring seat (5) from the spring barrel case (21).
8. Unscrew the spring adjuster (11) from the adjuster screw assembly (32).
9. Remove the spring adjuster screw nut (6) to free the yoke (31) from the spring barrel case (21).

10. Unscrew the spring adjuster screw (32) from the bridge of the spring barrel case.

ASSEMBLY

Preliminary Assembly

(If the actuator is completely disassembled):

1. Examine the bushing in the spring adjuster screw (32), and replace it if necessary.
2. Screw the spring adjuster screw (32) into the bridge of the spring barrel case (21) so that about two inches of the screw (non-bushed end) protrudes below the spring barrel bridge.
3. Guiding the spring adjuster screw (32) into the clearance hole in the top of the yoke (31), seat the spring barrel case (21) on the yoke.
4. Screw the spring adjuster screw (32) upward so that when the spring adjuster screw nut (6) is tightened only one thread of the screw will be visible below the nut (6).
5. Apply the nut (6) to the spring adjuster screw and tighten it securely.
6. Screw the spring adjuster (11) (convex side down) onto the spring adjuster screw (32) so that it is opposite the lower end of the dust cap slot (ref. 16).
7. Place the spring seat (5) and spring (29) on the spring adjuster (11).

Final Assembly

The following steps cover final assembly of the actuator after preliminary assembly, or after the actuator has been partially disassembled for replacement of the diaphragm only.

8. Prepare the actuator stem assembly for insertion into the spring barrel as a unit.
 - a.) Inspect the diaphragm (15) and replace it if necessary.
 - b.) Slide the diaphragm plate (8) (flat side up) over the actuator stem (20) to rest on the shoulder of the stem.
 - c.) Dust the diaphragm thoroughly with talcum to prevent abrasion, then place the diaphragm (convex side up) over the spring stem to rest on the diaphragm plate. The mold of the diaphragm will cause it to drape downward from the edge of the plate.
 - d.) Place the diaphragm-washer (18) (rounded corners down) over the actuator stem, then lock the assembly together with the actuator stem nut (17).
 - e.) Invert the actuator stem assembly and slide the upper travel stop (30) over the stem.
9. Holding the travel stop (30) on the stem, lower the actuator stem into the spring adjuster screw (32).

Note: After the stem has been started into the adjuster screw, drop the travel stop (30) to rest on the adjuster screw top, then guide the diaphragm plate boss into the spring.

10. Line up the holes in the diaphragm with the cap screw holes in the spring barrel case (21).

Note: To facilitate assembly, the spring adjuster (11) can be turned upward or downward (to reposition the spring) so that the diaphragm drapes smoothly onto the cap screw flange.

11. Place the diaphragm case (1) on the diaphragm, positioning the air connection and aligning the cap screw holes with those in the diaphragm and lower case.
12. Insert the cap screws and nuts (9 & 10), and tighten all nuts evenly and securely to ensure a tight diaphragm seal.
13. Replace the dust cap (16), and the actuator is ready for mounting on the valve body.

ADJUSTMENTS

Adjusting Actuator Stroke

1. Determine the valve travel from the nameplate; add $\frac{1}{16}$ ", and call this dimension "D."
2. Apply about 30 psig air pressure to the chamber above the diaphragm in order to extend the stem as far as it will go.

Note: Ensure that stem travel has been stopped by the upper travel stop (30) by turning the spring adjuster (11) downward (with a screwdriver inserted through the dust cap slot) to relieve any spring compression.

3. Screw the travel stop nut (3) onto the actuator stem (20) and position the nut so that its top surface is below the end of the spring adjuster screw (32) by a distance equal to "D." (See Step 1, above.) Tighten the travel stop nut set screw (19) securely.
4. Exhaust all air pressure from the chamber above the diaphragm.

Setting the Inherent Diaphragm Pressure Range

This adjustment consists of compressing the spring (with the stem fully retracted) just enough to counterbalance the downward thrust of the diaphragm when air pressure in the upper chamber is at the lower value of the range. Once this starting point for actuator stem movement has been established, the spring design ensures that the stem will be fully extended (in accordance with "D," see item 3 in the previous section) when air pressure reaches the upper range value.

1. Connect an air gauge and a 0-60 psi regulator to an air line leading to the chamber above the diaphragm.

2. Insert a screwdriver through the dust cap slot and turn the spring adjuster (11) upward until there is definite indication of spring compression.
3. Determine the lower value of the diaphragm pressure range from the nameplate.
4. Gradually increase air pressure to the upper diaphragm chamber, and determine at what pressure the actuator stem starts to move downward.

Note: Use one hand to regulate air pressure and the other to touch both the actuator stem and the end of the spring adjuster screw (32).

Setting the Installed Diaphragm Pressure Range (Single Seated Valve Actuation)

As standard factory procedure, single seated valves are tested for shutoff against the maximum inlet pressure stated on the order. The actuator furnished provides ample power to handle the specified flow conditions at the diaphragm pressure range stamped on the nameplate.

Under actual operating conditions line pressure differentials may differ from the calculated figures. This may require a change in the diaphragm pressure range in order to obtain full valve travel and shutoff.

- a.) On Pull-Stem-to-Open valves, the Direct Actuator usually requires only an increase of the air pressure range values to compensate for pressure drops slightly greater than calculated.
- b.) On Push-Stem-to-Open valves, the Direct Actuator may require increased initial spring compression to ensure shutoff. (Accomplished by turning the spring adjuster (11) with a screwdriver.) Diaphragm pressure range values must consequently be increased to counterbalance the greater spring force.

Adjust spring compression by moving the spring adjuster (11), and again increase air pressure gradually. Repeat this testing and adjusting procedure until the actuator stem just starts to move as the increasing air pressure passes the lower value of the pressure range. The inherent diaphragm pressure range has now been established.

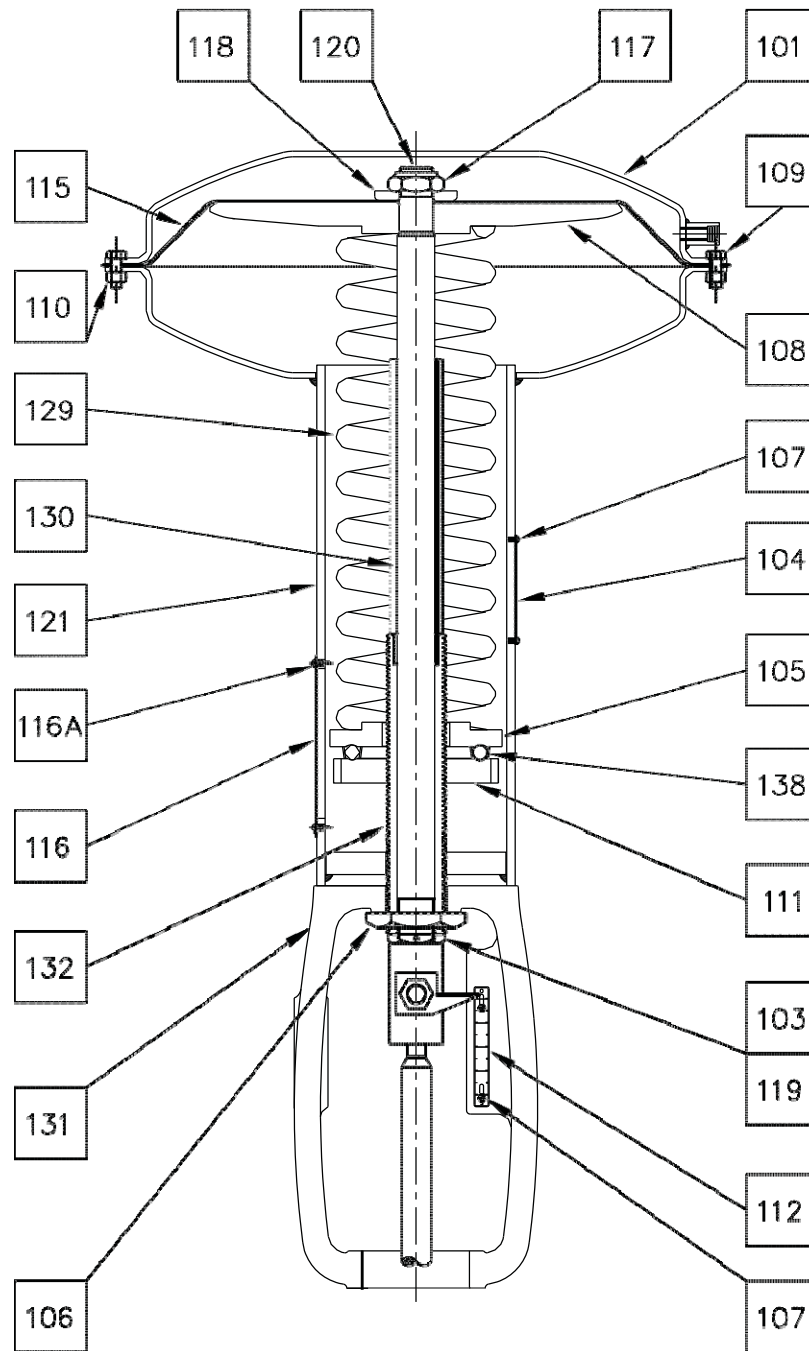

Pneumatic Diaphragm Direct Actuator

FIGURE 1: PARTS IDENTIFICATION

TABLE 1: PARTS LIST

ITEM	DESCRIPTION	QTY	MATERIAL	ITEM	DESCRIPTION	QTY	MATERIAL
81	LIFT EYE BOLT (not shown)	2	STEEL	115	MOLDED DIAPHRAGM CASE	1	BUNA-N
100	STEM CONNECTOR	1	STEEL	116	DUST COVER	1	300 SS
101	DIAPHRAGM CASE ASSY.	1	STEEL	116A	SCREW RD HD, $\frac{6}{32} \times \frac{1}{4}$ "	2	STEEL
103	HEX NUT 1¼-12	1	STEEL	117	LOCK NUT 1½-12UNF-3B	1	STEEL
104	I.D. PLATE GLOBE VALVE	1	300 SS	118	DIAPHRAGM WASHER	1	STEEL
105	SPRING SEAT	1	STEEL	119	SOCKET HEAD SET SCREW	1	STEEL
106	HEX NUT 2-12	1	STEEL	120	ACTUATOR STEM	1	STEEL
107	NAME PLATE SCREWS	6	316 SS	121	SPRING BARREL CASE ASSY	1	STEEL
108	DIAPHRAGM PLATE	1	CAST IRON	129	ACTUATOR SPRING	1	STEEL
109	HHC SCREW $\frac{3}{8}$ -16x1.00"	28	STEEL	130	TRAVEL STOP	1	STEEL
110	HEX NUT $\frac{3}{8}$ -16	30	STEEL	131	YOKE	1	CAST IRON
111	SPRING ADJUSTER	1	CAST IRON	132	SPRING ADJUSTING SCREW	1	STEEL
112	TRAVEL IND. SCALE 3.50"	1	300 SS	138	BALL THURST RETAINER	1	STEEL

Pneumatic Diaphragm Direct Actuator with Side-Mounted Handwheel
FIGURE 2: PARTS IDENTIFICATION

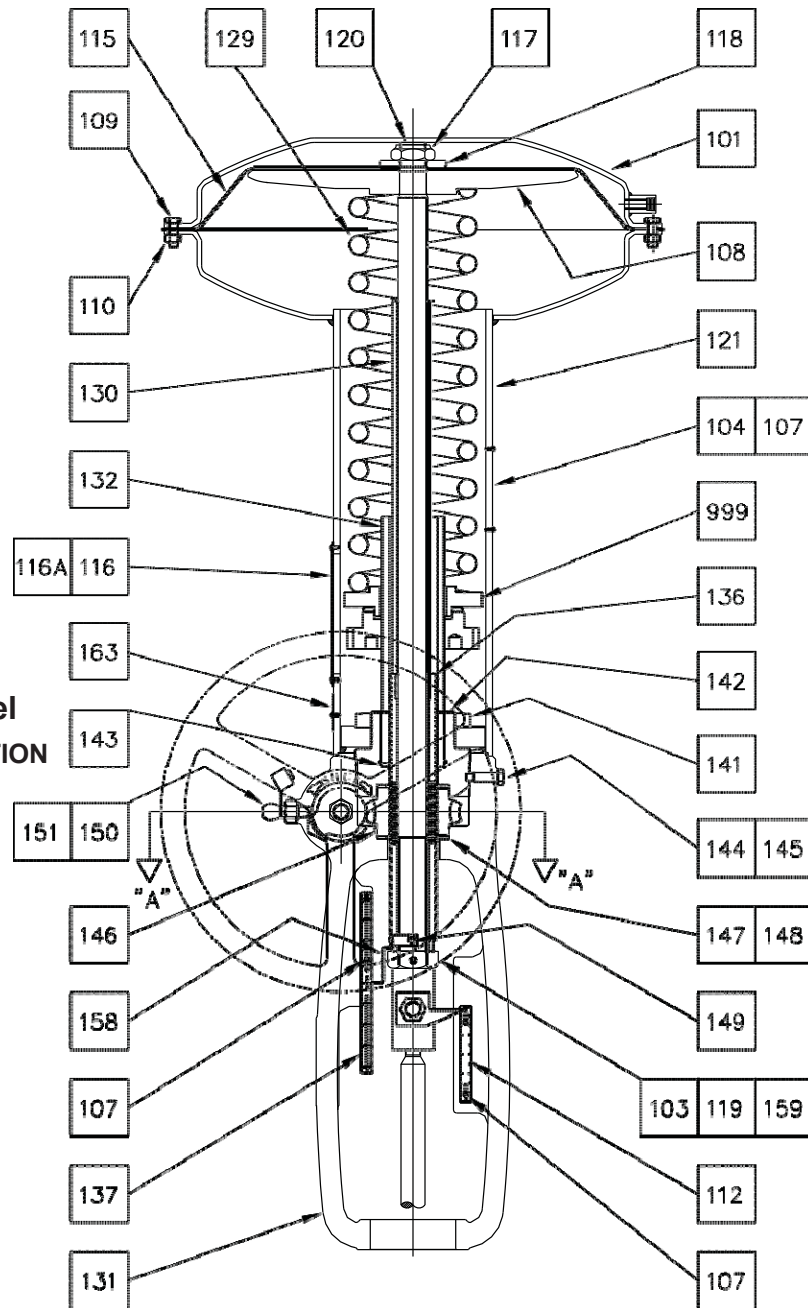

TABLE 2: PARTS LIST

ITEM	DESCRIPTION	QTY	MATERIAL	ITEM	DESCRIPTION	QTY	MATERIAL
81	LIFT EYE BOLT (not shown)	2	STEEL	131	YOKE	1	CASTIRON
101	DIAPHRAGM CASE ASSY.	1	STEEL	132	SPRING ADJUSTING SCREW	1	STEEL
103	HEX NUT 1¼-12	1	STEEL	136	JACKING SCREW ASSY	1	STEEL
104	I.D. PLATE GLOBE VALVE	1	300 SS	137	HANDWHEEL TRAVEL IND. SCALE	1	300 SS
107	NAME PLATE SCREWS	6	316 SS	141	CLAMP NUT 3 ½-12	1	STEEL
108	DIAPHRAGM PLATE	1	CASTIRON	142	BEARING RETAINER	1	STEEL
109	HHC SCREW ¾-16×1.00"	28	STEEL	143	JACK SCREW KEY	1	STEEL
110	HEX NUT ¾-16	30	STEEL	144	SCREW ¾-16×1 7/16	1	STEEL
112	TRAVEL IND. SCALE 3.50"	1	300 SS	145	SPLIT LOCKWASHER, ¾" LIGHT S.Z.P.	1	STEEL
115	MOLDED DIAPHRAGM CASE	1	BUNA-N	146	WORM GEAR	1	CASTIRON
116	DUST COVER	1	300SS	147	THRUST BEARING	2	STEEL
116A	SCREW RD HD, 5/32 × ¼"	2	STEEL	148	THRUST RACE	4	STEEL
117	LOCK NUT 1 ½-12UNF-3B	1	STEEL	149	TRAVEL IND. SCREW, 6-32 × 3/16 S.Z.P.	2	STEEL
118	DIAPHRAGM WASHER	1	STEEL	150	GREASE FITTING	1	STEEL
119	SOCKET HEAD SET SCREW	1	STEEL	151	GREASE CAP POLYETHYLENE	1	POLYETHYLENE
120	ACTUATOR STEM	1	STEEL	158	TRAVEL INDICATOR	1	BRASS
121	SPRING BARREL CASE ASSY	1	STEEL	159	SET SCREW DISC	2	COPPER
129	ACTUATOR SPRING	1	STEEL	163	COVER PLATE	2	ALUMINUM
130	TRAVEL STOP	1	STEEL	999	SPRING ADJUSTER ASSY, 2.63"-12UN-2B	1	STEEL

Notes:

control valves
KOSO HAMMEL DAHL

KOSO HAMMEL DAHL
253 Pleasant Street W.
Bridgewater, MA 02379

Telephone: 774.517.5300
Fax: 774.517.5230
www.hammeldahl.com