

KOSO HAMMEL DAHL

CONTROL VALVES

KOSO HAMMEL DAHL
253 Pleasant Street
West Bridgewater, MA 02379

tel: 774.517.5300
fax: 774.517.5230
www.hammeldahl.com

Installation, Maintenance & Operating Instructions

IMO - LS Type 1

Type 1 Limit Stop for Linear Spring Diaphragm Actuators

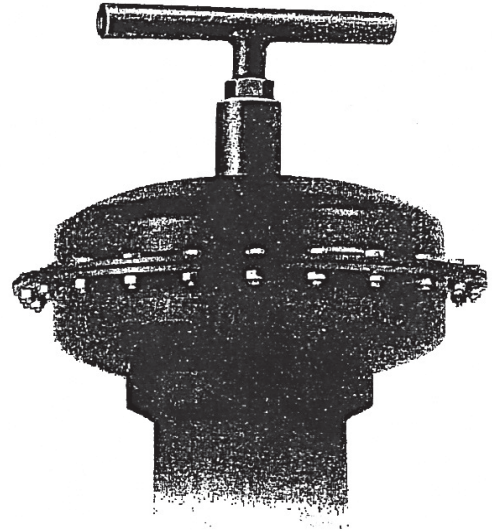

Read these instructions carefully before installation or servicing.

WARNING !

FOR YOUR SAFETY AND PROTECTION, IT IS IMPORTANT THAT THE FOLLOWING PRECAUTIONS BE TAKEN PRIOR TO DOING ANY WORK ON THE ACTUATOR:

1. Service pressure must be shut off.
2. Bleed the service line.
3. Remove the service line connectors from the actuator.
4. Do not start any disassembly until the actuator is depressurized.
5. Wear any protective clothing or equipment normally required when working with the media involved.
6. If disassembly of the actuator goes beyond what is covered in the IMO, refer to the IMO applicable to the actuator or accessory.

Parts

Item No.	Description	Qty.
1	Limit Stop Diaphragm Case Assembly	1
2	Stem Assembly	1

3*	Thread Sealing Washer
4	Hex Nut

**Direct acting actuators only*

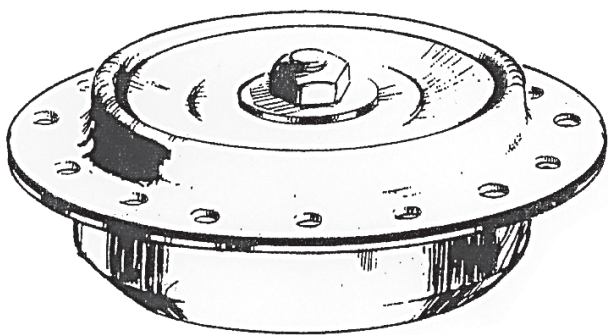

DIRECT ACTING

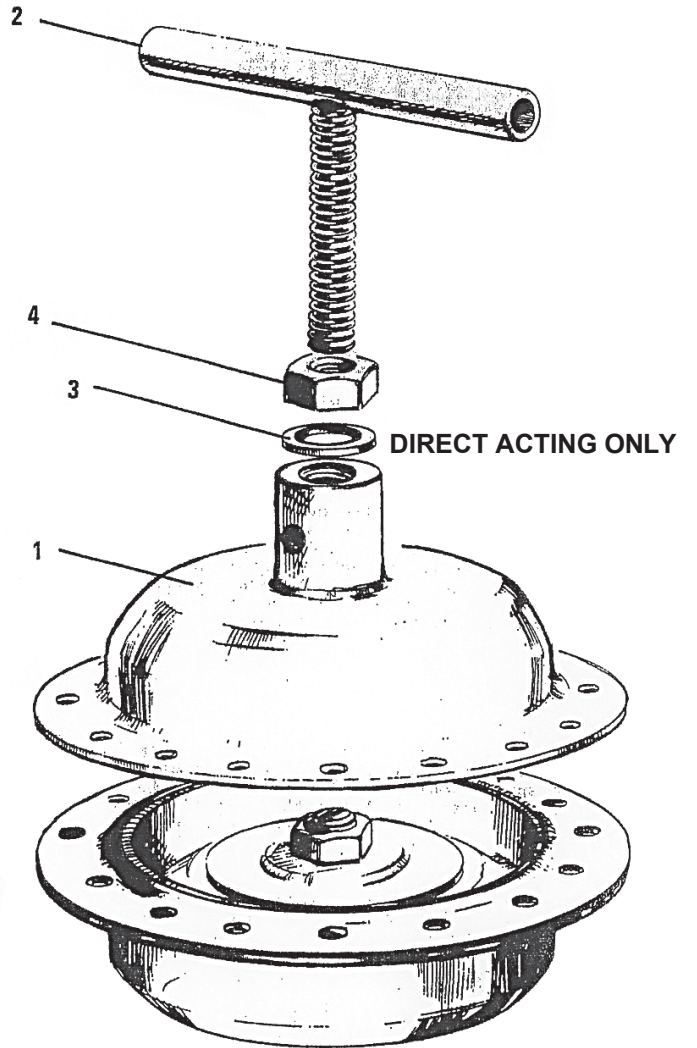

REVERSEACTING

PRINCIPLES OF OPERATION

Type 1 limit stops are used with linear diaphragm actuators to limit spring stem retraction. When applied to a direct acting actuator, the pneumatic force and limit stop force add, and are opposed by the spring force.

Normally the limit stop is adjusted with the pneumatic force and the spring force in a “null” condition at the desired limit stop position, so the adjustment is made under “no load” conditions. It should be noted, however, that the limit stop is capable of jacking up against any spring which it might normally oppose. Repeated use of a limit stop as a manual override is not recommended because of potential thread wear.

The Type 1 limit stop, when applied to direct acting actuators, includes a thread sealing washer to prevent leakage of air from the upper diaphragm chamber.

When applied to a reverse acting actuator, the spring force and the limit stop force add, and are opposed by pneumatic force. In the absence of pneumatic pressure, the spring would move the spring stem to the fully extended position, hence there would be no force resisting limit stop adjustment. Ideally, sufficient pneumatic pressure would be available to bring the spring stem to the desired limit stop position so that accurate positioning is easily achieved. Once the limit stop has been set and locked in position, the limit stop will be capable of handling the rated pneumatic pressure of the diaphragm case.

INSTALLATION

To install the Type 1 limit stop as a substitute for the upper diaphragm case, refer to the drawings in either IMO - Type D or R and proceed as follows:

1. Remove all pneumatic lines or accessories connected to the upper diaphragm case (4).
2. Remove all diaphragm case cap screws (17) and nuts (18) and lift the upper diaphragm case (4) away.
3. Place the Type 1 limit stop assembly in position over the diaphragm (2) and lower the diaphragm case (5) so that the bolt holes are in proper alignment.

Note: *The limit stop stem subassembly (2) should be fully retracted.*

4. Reinstall the diaphragm case cap screws (17) and nuts (18) and tighten to 22-26 lbf using good flange bolt tightening practice.
5. Set the limit stop stem (2) at the desire position in accordance with the details provided above under “Principle of Operation.”
6. Reinstall any required pneumatic lines or

IMO- LS Type1

Rev 1 3/21

accessories.

DISASSEMBLY

1. Back off the hex nut (4).
2. Unscrew the limit stop stem assembly (2).

REASSEMBLY

1. Lubricate the threads of the limit stop stem assembly (2) with a heavy automotive type grease.
2. Screw the limit stop stem assembly (2) down into the diaphragm case assembly (1). Wipe off excess lubricant.
3. Adjust the limit stop stem assembly (2) as required.
4. Turn the thread seal washer (3) down on the limit stop stem (2) until it makes firm contact with the upper face of the diaphragm case assembly hub (1).
5. Turn the hex nut (4) down to the thread seal washer (3) and lock in position.

Note: *When Type 1 limit stops are mounted on reverse acting actuators, the thread seal washer (3) is deleted.*

For instruction on disassembling the major portion of the actuator, refer to IMO-Type D for direct acting actuators, and to IMO-Type R for reverse acting actuators.

LUBRICATION

Any good petroleum base grease will be satisfactory. The only item that should be greased is the jacking screw.

KOSO HAMMEL DAHL CONTROL VALVES

KOSO HAMMEL DAHL
253 Pleasant Street
W. Bridgewater MA 02379

Telephone: 774.517.5300
Fax: 774.517.5230
www.hammeldahl.com

KOSO VECTOR **kentintrol**[™]

PSA
ELECTRAULIC[™] ACTUATION

PARCOL