

KOSO HAMMEL DAHL

CONTROL VALVES

KOSO HAMMEL DAHL
253 Pleasant Street
West Bridgewater, MA 02379

tel: 774.517.5300
www.hammeldahl.com

Installation, Maintenance & Operating Instructions

IMO - G110

1-1/2" - 16" SERIES G110
GLOBE and ANGLE STYLE
ANSI CLASS 150, 300 & 600

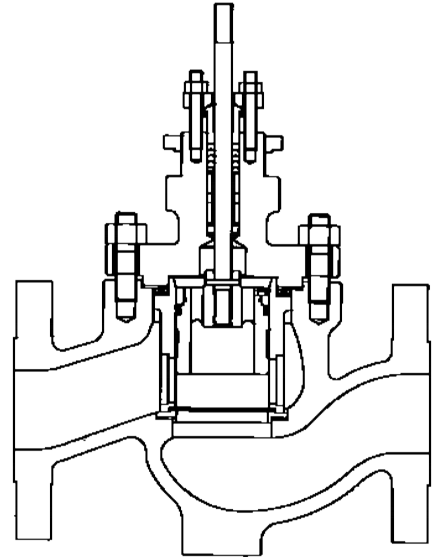

Read these instructions carefully before installation or servicing.

WARNING !

FOR YOUR SAFETY AND PROTECTION, IT IS IMPORTANT THAT THE FOLLOWING PRECAUTIONS BE TAKEN PRIOR TO REMOVING THE VALVE FROM SERVICE OR BEFORE ANY DISASSEMBLY OF THE VALVE:

1. At all times during this procedure, keep hands out of the valve. A remotely actuated valve could close at any time and result in serious injury.
2. Know what media is in the line. If there is any doubt, check with the proper authority.
3. Wear any protective clothing or equipment normally required when working with the media involved.
4. Depressurize the line and valves as follows:
 - a. Open the valve and drain the line.
 - b. Close and open the valve to relieve any residual pressure that may be in the valve prior to removing the valve from service.
 - c. After removal and prior to any disassembly, drain any remaining media by placing the valve in a vertical position and carefully opening and closing the valve several times.
5. The practical and safe use of this product is determined by the trim, packing, seal rings and body ratings. Read the name tags and check the maximum temperature and rating listed. This product is available with a variety of trim materials. Some of the trim materials have pressure ratings that are less than the body ratings. All of the body and trim ratings are dependent on valve type and size, packing, seal rings, trim material, bolting material, and temperature. Do not exceed these ratings.



TABLE OF CONTENTS

Introduction	3
General	3
Storage	3
Unpackaging	3
Installation	3
Final Check.....	3
Disassembly	4
Removal from Pipeline.....	4
Actuator Removal.....	4
Valve Body Disassembly	5
Maintenance/Repair	5
Replacement of Soft Seat	5
Plug Seal Removal	5
Plug/Stem Disassembly.....	5
Packing Box	5
Live-Loaded Packing Designs	6
Bellows Sealed Valves	7
Valve Body Assembly	7
Plug Seal Assembly	7
Plug/Stem Assembly.....	7
Body Assembly	7
Actuator Mounting and Adjustment	8
Actuator Mounting	8
Establishing Seat Load	8
Valve/Actuator/Travel	8
Actuator Bench Set and Span	8

These instructions provide information about safe handling and operation of the valve and are subject to change without notice.

INTRODUCTION

The following instructions should be thoroughly reviewed and understood prior to installing, operating, or performing maintenance on this equipment. Throughout the text, safety and/or caution notes will appear and must be strictly adhered to; otherwise, serious injury or equipment malfunction could result.

A regularly scheduled training program is conducted to train customer service and instrumentation personnel in the operation, maintenance and application of control valves and instruments. Arrangements for these services can be made through your local representative. When performing maintenance, use only KOSO AMERICA replacement parts. Parts are obtainable through your local representative. When ordering parts, always include model and serial number of the unit being repaired. The model number, serial number, size, and rating of the valve are shown on the identification tag located on the actuator.

General

These installation and maintenance instructions apply to all sizes and ratings of the G110 Series control valves regardless of the type of trim used. These instructions assume this valve has been supplied with a KOSO HAMMEL DAHL D/R Series pneumatic actuator. However, this valve is available with other types of actuators. When an actuator other than the D/R series has been provided, refer to the actuator manufacturer's literature for proper installation, maintenance, and operation instructions.

Storage

1. When a valve is to be stored for an extended period, remove the line connection covers, and spray a light coating of rust inhibitor on the internals. Replace the covers to prevent foreign matter from entering the valve body. Exposed parts should also be sprayed with a protective film of oil.
2. A packing list, containing a complete description of the valve and accessories (such as a valve positioner, etc.), accompanies each valve when shipped. This list should be checked soon after the shipment has been received.
3. When hoisting the valve, make sure that ropes or cables are of sufficient strength and are positioned so that any tubing or accessories will not be damaged.

Unpackaging

Care must be exercised when unpacking the valve to prevent damage to the accessories and component parts. Should any problems arise, contact your local representative.

INSTALLATION

1. The best performance will be obtained if the valve is installed in a straight run of pipe away from elbows, restrictors, or other areas where abnormal velocities may occur. The valve may be installed in any position; however, the vertical upright position is strongly recommended.
2. There should be at least one foot of clearance above the actuator in order to perform in line maintenance operations.
3. A conventional three valve bypass should be installed for systems which must continue in service during periods of control valve maintenance.
4. Care should be taken in rigging the valve for installation to assure that instruments or instrument lines are not damaged.
5. Before installing the valve in the line, clean the piping and the valve of all foreign material such as welding chips, scale, oil, grease, or dirt. Gasket surfaces should be thoroughly cleaned to insure leak-proof joints.
6. Pipe threads should be clean and sharp. Apply pipe compound or joint sealer to the male threads only. Be sure that the compound or sealer is compatible with the process fluid.
7. The valve must be installed so that the media will flow through the valve in the direction indicated by the flow arrow located on the body.
8. Where insulation of the valve body is required, **DO NOT INSULATE THE VALVE BONNET.**
9. An air supply pressure regulator with filter should be installed in the air line ahead of any valve-mounted instruments. Factory mounted positioners are piped and adjusted at the factory.

Final Check

1. Turn on the instrument air supply and (a) for reverse actuators, set pressure 5 psig greater than required by the bench set listed on the label plate, or (b) for direct actuators, see valve data sheet for air pressure setting.
2. Check the air lines to the actuator for leaks.
3. Vary the air supply or control signal to the actuator to ascertain that the actual valve travel (stroke) corresponds with the data in Table 1.

4. Check to be sure that the combined actions (direct and reverse) of the controller, positioner, etc. and valve, produce desired direction of movement, and will ensure the required valve position in the event of air supply failure.

NOTE: Under actual operating conditions the pressure drop across the valve may differ from the calculated figures. Some actuators may require readjustment of the spring preload in order to provide adequate shutoff force. In this situation check to ensure that the actuator is still capable of full valve travel with the available supply air pressure.

5. Tighten the packing flange stud nuts evenly to assure optimum sealing pressure on the stem and packing box walls. In most cases, packing flange stud nuts should be tightened within the range shown in Table 5 to provide adequate sealing and prevent packing box leakage. Refer to Packing Box instructions for additional information (page 6). Over tightening will restrict stem movement and adversely affect the process control.

DISASSEMBLY

Read these instructions completely. For your safety, it is important that the following precautions be taken prior to removal of the unit from the line or before any disassembly.

1. Wear any protective equipment normally required when working with the fluid involved during removal and disassembly.
2. Depressurize and drain the pipeline with the valve open prior to disconnecting service lines.
3. Before removing the instrument connections from the actuator, shut off the air pressure and bleed the air lines.
4. Have adequate rigging transport means available at the valve before attempting to remove it from the pipeline or before breaking the body/bonnet joint for in-line service.

Removal from Pipeline (for flanged end valves)

NOTE: Maintenance such as diaphragm, packing or trim replacement can be done without removing the valve from the line.

1. Disconnect all instrument air and electrical lines from the actuator.
2. Remove all inlet and outlet line flange studs and nuts and lift the valve out of the pipeline.
3. Secure the valve and actuator assembly firmly on a work bench in an upright position in a manner to prevent tipping or falling over.

Actuator Removal

1. For reverse acting actuator: Connect instrument air to the actuator and apply signal pressure sufficient to move the plug to a position only slightly off the seat. This will remove the spring force from the coupling before disassembly.
2. Disconnect the actuator coupling from the valve stem by disengaging the coupling bolts (Figure 1). Disconnect air supply.

CAUTION: In reverse acting actuators, the stem and plug may move when air supply is removed.

3. Unscrew the clamp nut from the bonnet by placing a metal rod or blunt nosed chisel on the clamp nut lugs and striking with a mallet.
4. Unbolt the clamp nut from the stems and lift the nut over the plug stem.
5. Lift or hoist the actuator unit off the valve, taking care to avoid damaging the plug stem, instruments, or tubing.

NOTE: The actuator is removed from the body as a unit, without disturbing the packing box bolt-bolting. Clamp nut and actuator yoke will pass over the packing flange.

6. If maintenance is required on the actuator consult the appropriate actuator IMO.

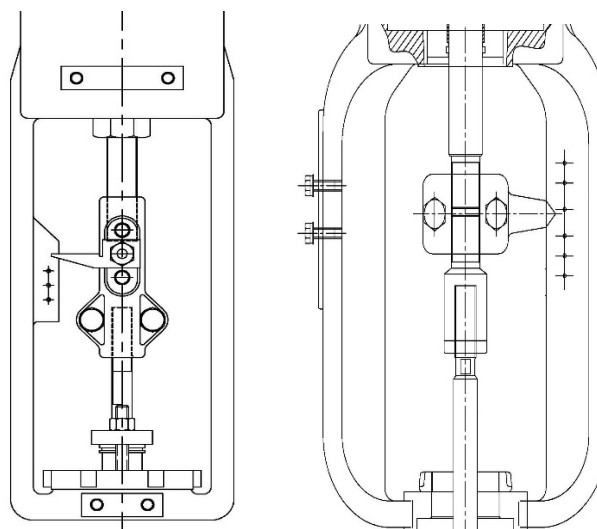

D/R actuator

D52/R52 actuator

FIGURE 1 Actuator Removal

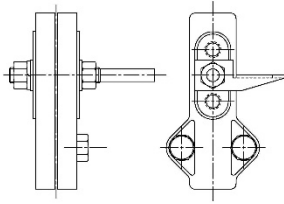
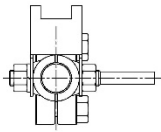

D/R stem connector

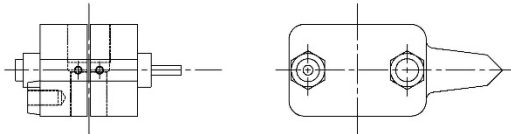
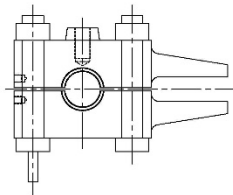

D52/R52 stem connector
FIGURE 2 Stem Connector

VALVE BODY DISASSEMBLY

1. Unscrew the packing flange nuts and remove packing flange and packing follower.
2. Remove the bonnet/body stud nuts.
3. Lift the bonnet while holding the plug stem, (to prevent the plug from dropping out) carefully lift off the valve body. Remove the cage and the seat ring from the body.
4. Withdraw the plug and stem downward out of the bonnet.

CAUTION: Care must be taken to avoid damage to the plug and stem.

5. Using a narrow hook or bent wire, pull the packing rings and lantern ring/spacer out of the packing box.

CAUTION: When removing packing rings from the packing box, use a hook, bent wire or tool which is softer

than the bonnet material to prevent scratching or marring of the packing box surfaces.

6. Clean the packing box thoroughly before replacing packing.
7. Bonnet, plug, cage, and seat ring may now be inspected for wear and service damage. After determining the maintenance required, proceed to the appropriate section of this IMO.

MAINTENANCE/REPAIR

The purpose of this section is to assist maintenance personnel by suggesting methods of component maintenance which may be largely dependent on the tools and machine shop equipment available. Each section should be read and understood before proceeding.

Replacement of Soft Seat

The soft seat insert is captured between the upper surface of the seat ring and the lower surface of the cage. No special parts or tools are required.

Plug Seal Removal

1. The standard TFE/o-ring seals and the metal rings are a one-piece ring which incorporate a lap joint. The rings may be removed from the plug grooves using a narrow hook or bent wire made of a soft material.
2. The carbon rings are a two-piece design that may be removed using a narrow hook or a bent wire of soft material.
3. The cup seal is a one-piece design and is installed on the plug using a retaining ring. This retaining ring is threaded onto the valve plug and pinned in place. To remove the cup seal, knock out the pin with a punch and unscrew the retaining ring.

NOTE: *This cup seal is a one direction seal. Prior to removal note the direction of installation*

Plug/Stem Disassembly

1. Using a punch, drive out the pin, a drill bit somewhat smaller than the pin should be used to remove the remainder of the pin.
2. Unscrew the plug from the stem.

Packing Box

Packing box maintenance is one of the principle chores of routine servicing. Tightness of the packing is maintained by packing compression. Compression is achieved by evenly tightening the packing flange nuts against the packing flange. Care must be taken not to over tighten, as this could prevent smooth operation of the valve. If all compression is used up and the valve leaks, new packing is required.

In live-loaded packing, the compression is provided by the Bellville spring washers. Proper adjustment of the spring washers is required to achieve and maintain packing tightness.

Packing box maintenance may be performed as a part of major disassembly and repair or as a separate routine with the valve installed in the process line. In either case the following steps should be closely adhered to, otherwise serious injury or equipment damage could result.

CAUTION: Valve must be isolated, and the pressure vented before performing packing box maintenance.

1. Loosen and remove packing flange nuts.
2. Raise packing flange and packing follower up the valve stem.

NOTE: *If the new packing rings are solid endless rings (i.e.: TFE V-ring, grafoil, etc.), the actuator stem coupling will have to be disconnected. Refer to the actuator removal section of these instructions for details of coupling removal. If the coupling is to be removed, the packing box flange and follower can be removed completely.*

3. Using a narrow hook or bent wire, pull the old packing rings and lantern ring or spring out of the packing box.

CAUTION: When removing packing rings from the packing box, use a hook, bent wire or tool which is softer than the bonnet material to prevent scratching or marring of the packing box surfaces.

4. Replace packing referring to Figures 4 - 9 for correct amount of packing and the correct sequence of installation.

NOTE: *A thin film of silicone lubricant will ease assembly.*

CAUTION: Avoid damage to packing ring when slipping them over the stem threads.

5. Slide the packing follower over the stem.
6. Place the packing flange, flat side up, over the stem and flange studs to rest on the packing follower.
7. Screw the packing flange nuts onto the studs and tighten them evenly to avoid cocking the flange.

NOTE: *An initial torque is place on the packing nuts to seal the packing box for testing purposes. When the valve is placed in service this adjustment should be checked, and the nuts tightened just enough to prevent any leakage. Excessive tightening will bind the valve stem and prevent sensitive response.*

Table 5 has typical minimum, and maximum torques for sealing during testing, for use as a reference guide.

8. In some applications, packing boxes are designed for use with a lubricator. The lubricator is provided with a ball check valve to prevent back flow of the process fluid. On some valves, an isolating valve is added for positive protection against back flow. The lubricator should be kept filled with the specified lubricant and turned in firmly but not tightly. One or two turns of the lubricator, once every two weeks should suffice to provide the desired seal.

Live-Loaded Packing Designs

1. Loosen and remove packing flange nuts.
2. Raise packing flange, packing follower and spring washers up the valve stem.

Note: *If the new packing rings are solid endless rings (i.e., TFE V-ring, grafoil, etc.), the actuator stem coupling will have to be disconnected. Refer to the actuator removal section of these instructions for details of coupling removal. If the coupling is to be removed, the packing box flange, follower and springs can be removed completely.*

3. Using a narrow hook or bent wire, pull the old packing rings and lantern ring or spring out of the packing box.

Caution: When removing packing rings from the packing box, use a hook, bent wire or tool which is softer than the bonnet material to prevent scratching or marring of the packing box surfaces.

4. Replace packing referring to Figures 8 or 9 for correct amount of packing and the correct sequence of installation.

Note: *A thin film of silicone lubricant will ease assembly.*

Caution: Avoid damage to packing ring when slipping them over the stem threads.

5. Replace DU bearing in the packing follower and slide over the stem.
6. Replace the spring washers in the proper orientation (refer to figures 8 and 9) for the packing material.
7. Place the packing flange over the stem and flange studs to rest on the packing follower.
8. Screw the packing flange nuts onto the studs and tighten them evenly to void cocking the flange.

Note: *Packing flange stud nuts should be tightened until the scribed line on the packing follower becomes visible above the packing flange.*

Bellows Sealed Valves

CAUTION: One end of the bellows is welded to the stem while the other end is welded to the flange. Any twisting of these two parts will result in damage to the bellows

1. Disassembly of a bellows sealed valve follows the same procedure as Valve Body Disassembly on page 4.
2. Damaged bellows assemblies are replaced as a complete unit.
3. If plug removal becomes necessary, carefully inspect the portion of the plug shank that can be seen below the flange. If the pin cannot be seen, the bellows assembly must be held in a vice and the stem moved downward slightly until the pinned connection is visible.

CAUTION: In the relaxed condition the bellows will be at mid travel. The stem may be moved downward 1/2 of the valve travel listed in Table 1.

4. Reassembly of a bellows sealed valve follows the same procedure as Valve Body Assembly.

VALVE BODY ASSEMBLY

After completion of the required maintenance the valve should be reassembled using the following procedures:

Plug Seal Assembly

1. The standard TFE/o-ring seals and the metal rings are a one-piece design incorporating a lap joint. Apply a light film of acceptable lubricant to the plug outside diameter. After the o-rings have been inserted into the piston ring grooves, start with one end of the seal, and feed the seal into the groove and mate the lap joints tightly. For lap joint seals arrange the lap joints so that the joints in the 2 rings are 180 degrees apart.
2. The carbon rings are supplied as two halves which have been "broken" at the factory. The halves should be cleaned and inserted directly into the piston ring grooves.

NOTE: Ensure that the broken halves remain in the same orientation so the ends will mate.

3. The cup seal is a one-piece design and must be installed using a "two-piece plug." Place the seal on the seal surface on the back of the plug ensuring that all surfaces are clean and smooth.

NOTE: This seal is a one-direction seal and must be installed in the proper orientation. If the flow through the valve is from under the seat ring, the opening of this seal must be facing upward toward

the stem on the plug. If the flow is from over the seat ring, the opening in this seal must be facing downward on the plug.

4. Screw the retaining ring onto the valve plug. Drill through the retaining ring and into the valve plug and insert the retaining pin.

Plug/Stem Assembly

1. Screw the stem completely into the plug.
2. Place the plug shank on a V-block and using a suitable size drill-bit, drill the stem using the hole in the plug as a guide.
3. Remove any burrs from the plug guide by making a slight counter-bore.
4. Select the correct size pin, apply a small amount of grease on it and press into the hole.

NOTE: The pin must be recessed approximately 1/16" below the plug guide surface.

5. After the plug has been pinned, it should be placed in a lathe to insure it is running "true." If it is not, strike the plug with a soft faced mallet to straighten.

Body Assembly

1. Clean gasket surfaces. Place gasket on gasket surface on body bridge. Insert seat ring and cage into body.
2. Lower the plug and stem assembly into the body.
3. Place new bonnet gaskets on the body and lower the bonnet carefully over the plug stem and body studs to its place on the body.

NOTE: The bonnet must be positioned so the packing flange studs are at a right angle to the flow center line.

4. Install the stud nuts and tighten them evenly to finger tight only.
5. Reinstall packing according to instruction on page 6.
6. Using the stem, move the valve plug up and down through the rated travel.

NOTE: If there is any evidence of binding, loosen the body stud nuts and reposition the bonnet until the binding disappears.

7. Tighten the body stud nuts to the proper torque listed in Table 1 using the tightening sequence in Figure 3.

NOTE: Tighten in 1/3 increments stopping after each sequence to check for binding as described in step 6 above.

ACTUATOR MOUNTING AND ADJUSTMENT

The following instructions are for the D/R and D52/R52 series spring/diaphragm actuator. Instructions for other actuators can be obtained from your local representative.

Actuator Mounting

1. Lower the actuator over the plug stem and packing flange to seat squarely on the bonnet shoulder.
2. Rotate the actuator to a convenient position, then screw the clamp nut onto the valve bonnet threads and tighten it securely.
3. Connect a regulated air supply to the actuator diaphragm connection. The supply should be at least 5 psig greater than the pressure needed to stroke the actuator.
4. The actuator must be in the down position on the down travel stop.

NOTE: For "R" or "R52" series actuators, the spring will maintain the actuator on the down travel stop and no air pressure is required. For "D" or "D52" series actuators, regulate the supply pressure to the actuator to move the actuator stem downward until the downward motion is the same as the travel listed in Table 1.

5. The valve plug must be on its seat while the actuator stem is being connected.
6. Press half of the actuator coupling against the actuator stem and valve plug stem so that each stem is engaged in the coupling half at least one stem diameter.
NOTE: It may be necessary to move the valve plug off its seat a slight distance in order to mesh the valve plug stem threads with the coupling threads.
7. Apply the other half of the coupling, carefully engaging threads, then insert the coupling cap screw and tighten it by hand (Refer to Figure 1).

Establishing Seat Load

1. Maintain the actuator stem at its lowest position of travel.
2. If the plug moved off the seat during the stem connection procedure, prevent the stem coupling from rotating, and unscrew the valve plug stem out of the coupling until the plug is seated.

CAUTION: Unscrew the plug stem until the seat is contacted. Do not continue to unscrew. Rotating the valve plug while in contact with the seat ring can cause destruction of the seat and galling.

3. Move the plug off the seat by adding air supply to the "R" or "R52" series actuator or decreasing air supply to the "D" or "D52" series actuator.

Unscrew the valve plug stem an additional one-half turn out of the actuator coupling to ensure positive seating.

4. Tighten the connector cap screws securely.
5. Seat the valve plug firmly by means of the actuator.

IMPORTANT NOTICE

If these steps have been performed correctly the valve plug is on the seat ring, the actuator has been raised upward off its down travel stop, the actuator thrust is applied to the valve trim, and valve leakage will be within acceptable limits. If maintenance work has been performed and seat leakage is exceptionally high, these steps should be repeated in order to ensure that adequate seat load has been established.

Valve/Actuator/Travel

1. Adjust the travel indicator scale on the actuator yoke leg so that the "Shut" mark is opposite the travel indicator on the actuator stem coupling.
2. Stroke the valve/actuator combination by regulating the air supply to the diaphragm case. Note the travel on the indicator scale.
3. The actual travel should agree with the travels listed in Table 1.

NOTE: If the actual travel is less than the travel listed in Table 1, the actuator coupling should be removed and the steps in the previous sections repeated.

Actuator Bench Set and Span

1. The actuator bench set (spring preload) is stamped on the actuator identification tag located on the actuator leg.
2. Using a regulated air supply with a gage connected between the regulator and the diaphragm case, stroke the valve actuator combination.
3. Record the actuator air pressure at the actuator full up and full down position. This is the bench set and should agree with the bench set stamped on the identification tag.
4. If the actual bench set does not agree with the identification tag, the bench set can be adjusted by rotating the actuator spring adjuster.

The actuator spring span is the arithmetic difference between the bench set upper limit and lower limit.

TABLE 1							
Valve Size	Press Class	Valve Travel	Stud Size	Qty.	Req'd Torque lb-ft		Torque Sequence
					B7	B8M, CL2	
1-1/2"	Up to 600 CL.	1.12"	1/2 - 13	8	50 - 60	50 - 60	SEQ. 8
2"	Up to 600 CL.	1.12"	1/2 - 13	8	50 - 60	50 - 60	SEQ. 8
3"	Up to 600 CL.	1.50"	5/8 - 11	8	80 - 90	80 - 90	SEQ. 8
4"	Up to 600 CL.	1.50"	3/4 - 10	8	125 - 150	125 - 150	SEQ. 8
6"	Up to 600 CL.	2.25"	3/4 - 10	12	125 - 150	125 - 150	SEQ. 12
8"	Up to 600 CL.	3.50"	1 - 8	12	285 - 325	285 - 325	SEQ. 12
10"	Up to 600 CL.	3.50"	1 1/8 - 8	12	345 - 385	345 - 385	SEQ. 12
12"	150 - 300 CL.	3.50"	7/8 - 9	16	200 - 240	200 - 240	SEQ. 16
12"	600 CL.	3.50"	1 1/8 - 8	16	345 - 385	345 - 385	SEQ. 16
16"	Up to 600 CL.	10"	1 1/8 - 8	20	345 - 385	345 - 385	SEQ. 20

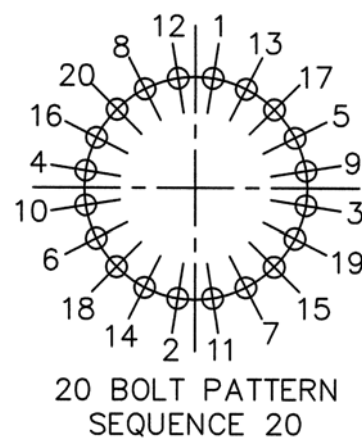
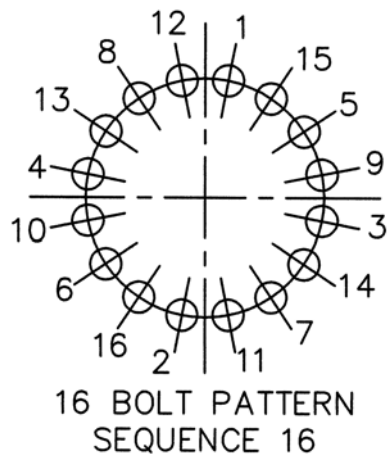
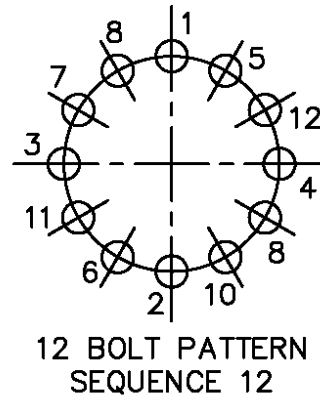
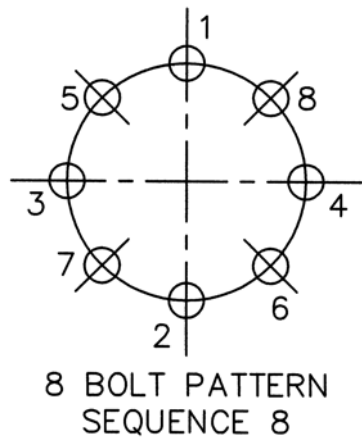
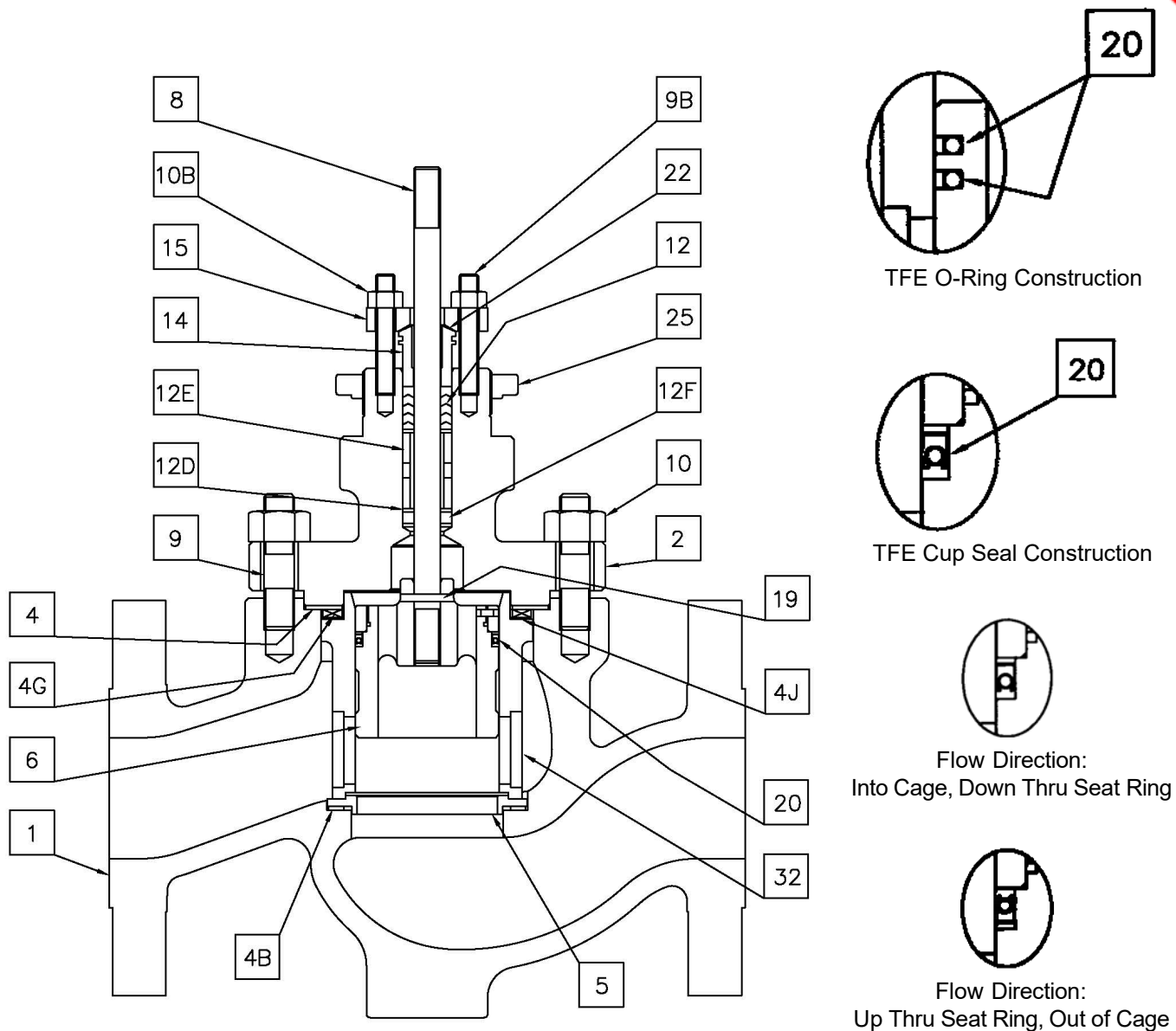

FIGURE 3 Bolt Tightening Sequence



**1-1/2" – 16" Series G110 - ANSI Class 150, 300 & 600
Cage Trim Globe and Angle Valves**

FIGURE 4 Parts Identification

TABLE 2						
PARTS LIST						
ITEM	DESCRIPTION	ITEM	DESCRIPTION	ITEM	DESCRIPTION	
1	Body	10	Body Stud Nut	22	Felt Wiper	
2	Bonnet	12*	Packing Set	23	Stud	
4*	Bonnet Gasket	12D	Washer	24	Nut	
4B*	Seat Gasket	12E	Packing Spacer	25	Clamp Nut	
4G*	BNT Backup Gasket	12F	Wiper Ring	32*	Cage	
4J*	Cage Gasket	13	Lantern Ring			
5*	Seat Ring	14	Packing Follower			
6*	Plug	15	Packing Flange			
8*	Stem	19*	Pin			
9	Body Stud	20*	Plug Seal			

* Recommended Spare Parts

NOTE: The seat ring in 10" - 16" valves is provided integral to the cage.

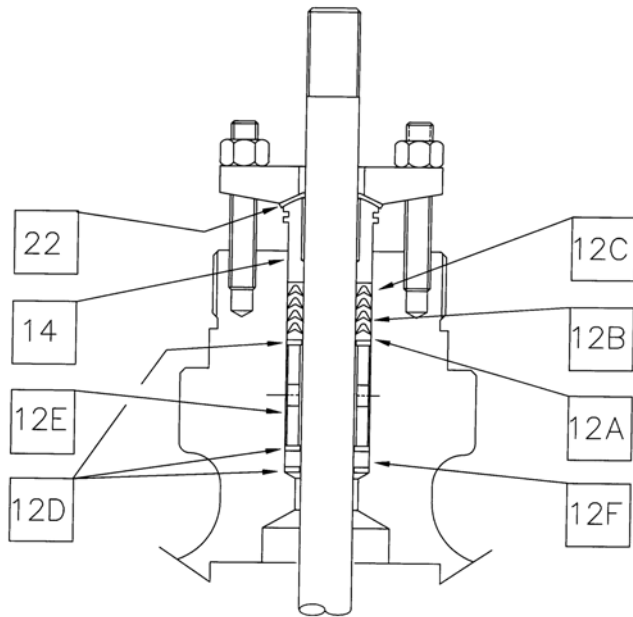

**TFE V-Ring
Single Set Packing
FIGURE 5**

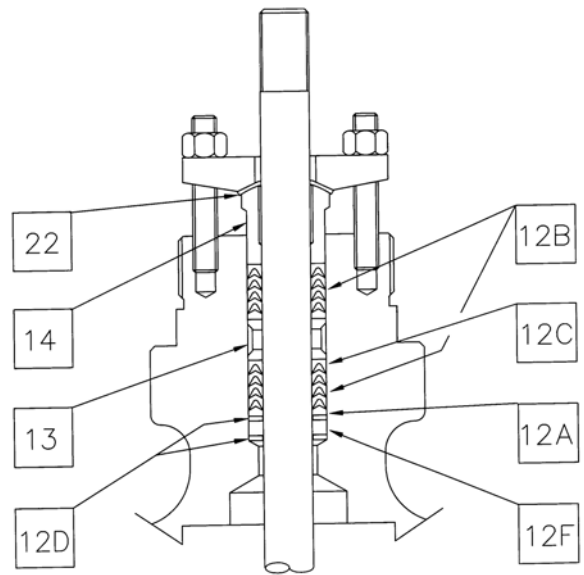

**TFE V-Ring
Double Sets Packing
FIGURE 6**

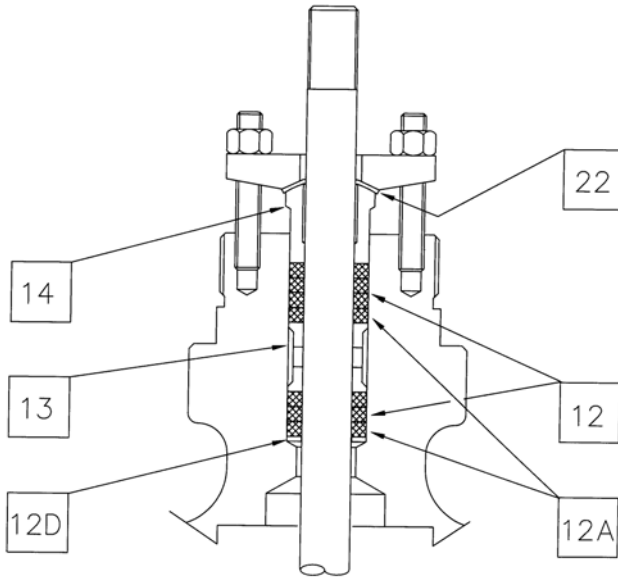

**Square Packing
FIGURE 7**

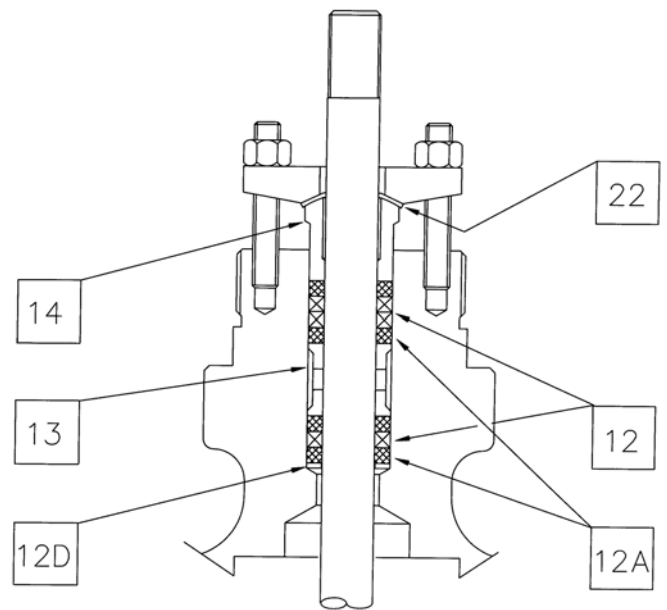

**Grafoil/Graphite
Standard Grafoil Packing
FIGURE 8**

TABLE 3			
Packing Sub-Assembly Parts List			
ITEM	DESCRIPTION	ITEM	DESCRIPTION
12*	Packing Set	12F*	Wiper Ring
12A*	Male Adapter	12G*	Packing Ring
12B*	V-Rings	13	Lantern Ring
12C*	Female Adapter	14	Packing Follower
12D	Packing Washer	22*	Felt Wiper
12E	Packing Spacer		

*Recommended Spare Parts

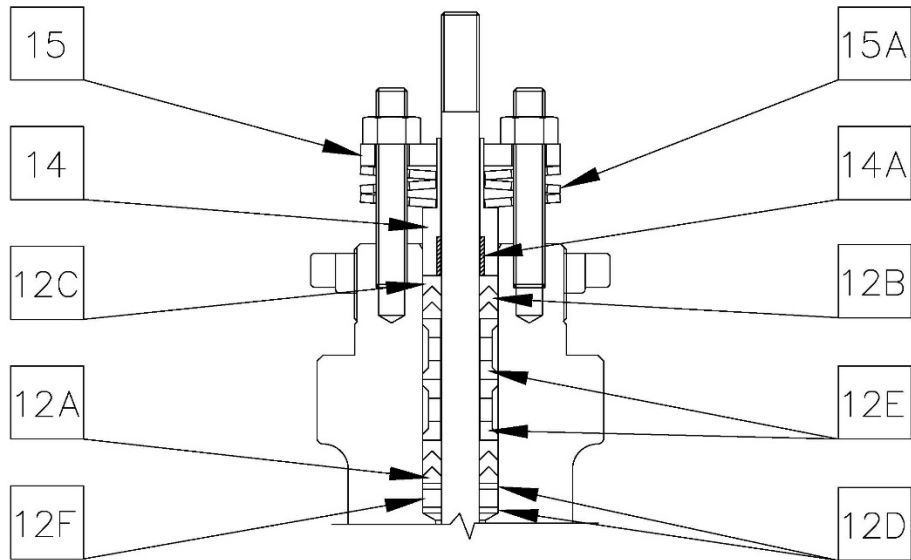

FIGURE 9. Live Loaded PTFE V-Ring Packing

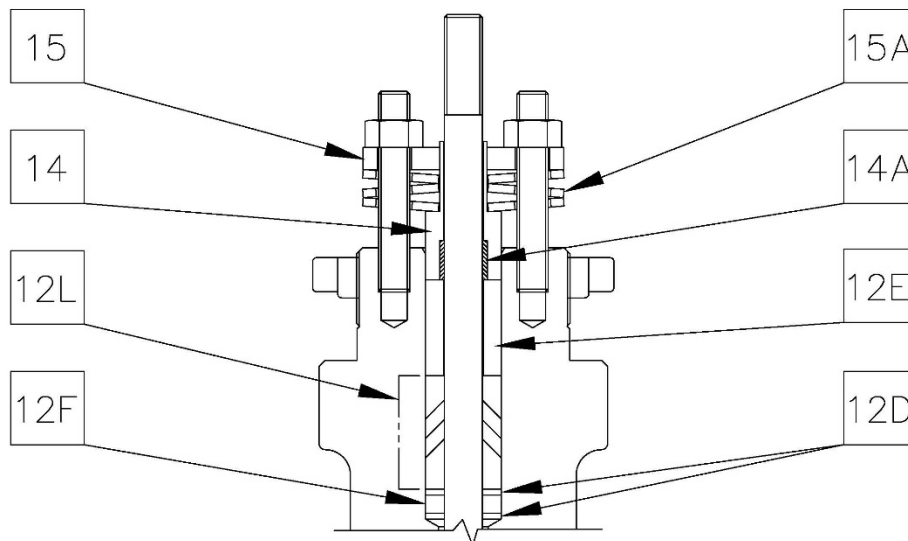

FIGURE 10. Live Loaded Grafoil Packing

TABLE 4			
Packing Sub-Assembly Parts List			
ITEM	DESCRIPTION	ITEM	DESCRIPTION
12*	Packing	12G*	Packing Ring
12A*	Male Adapter	12L*	Packing Set
12B*	V-Rings	13	Lantern Ring
12C*	Female Adapter	14	Packing Follower
12D	Packing Washer	14A	DU Bearing
12E	Packing Spacer	15	Packing Flange
12F*	Wiper Ring	15A	Spring Washers
*Recommended Spare Parts			

G110 Series Packing Torque

Valve Size	PTFE packing					
	ANSI 150#		ANSI 300#		ANSI 600#	
	Low Torque (in-lb)	High Torque (in-lb)	Low Torque (in-lb)	High Torque (in-lb)	Low Torque (in-lb)	High Torque (in-lb)
1-inch	2	40	5	40	10	40
1 ½-inch	2	40	5	40	10	40
2-inch	2	40	5	40	10	40
3-inch	3	40	5	40	15	40
4-inch	6	55	15	55	30	55
6-inch	9	85	20	85	45	85
8-inch	8	75	20	75	40	75
10-inch	11	100	25	100	55	100
12-inch	11	100	25	100	55	100
16-inch	9	85	20	85	45	85

Valve Size	Graphite Packing					
	ANSI 150#		ANSI 300#		ANSI 600#	
	Low Torque (in-lb)	High Torque (in-lb)	Low Torque (in-lb)	High Torque (in-lb)	Low Torque (in-lb)	High Torque (in-lb)
1-inch	4	180	10	180	20	180
1 ½-inch	4	180	10	180	25	180
2-inch	4	180	10	180	25	180
3-inch	6	220	15	220	30	220
4-inch	12	220	30	220	60	220
6-inch	18	220	45	220	95	220
8-inch	16	220	40	220	85	220
10-inch	22	220	55	220	115	220
12-inch	22	220	55	220	115	220
16-inch	19	220	45	220	95	220

TABLE 5.

Notes:

KOSO HAMMEL DAHL CONTROL VALVES

KOSO VECTOR kentintrol™

KOSO HAMMEL DAHL
253 Pleasant Street
W. Bridgewater MA 02379

Telephone: 774.517.5300
www.hammeldahl.com

REX
ELECTRAULIC™ ACTUATION

PARCOL