

# KOSO HAMMEL DAHL

CONTROL VALVES

KOSO HAMMEL DAHL  
253 Pleasant Street  
West Bridgewater, MA 02379

tel: 774.517.5300  
[www.hammeldahl.com](http://www.hammeldahl.com)

## Installation, Maintenance & Operating Instructions

### IMO V830/V831

1-1/2" 10" SERIES V830/V831  
3-WAY, GLOBE VALVE  
ANSI CLASS 150 600

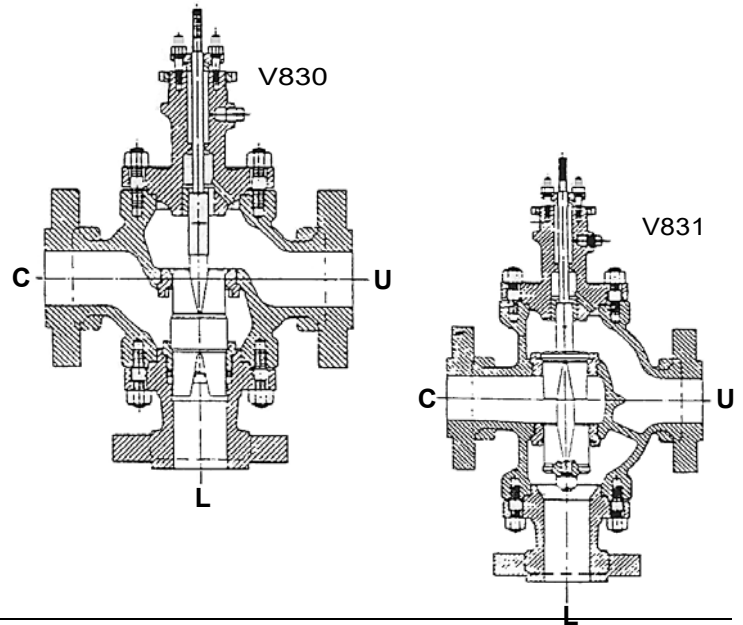

**Read these instructions carefully before installation or servicing.**

### **WARNING !**

**FOR YOUR SAFETY AND PROTECTION, IT IS IMPORTANT THAT THE FOLLOWING PRECAUTIONS BE TAKEN PRIOR TO REMOVING THE VALVE FROM SERVICE OR BEFORE ANY DISASSEMBLY OF THE VALVE:**

1. At all times during this procedure, keep hands out of the valve. A remotely actuated valve could close at any time and result in serious injury.
2. Know what media is in the line. If there is any doubt, check with the proper authority.
3. Wear any protective clothing or equipment normally required when working with the media involved.
4. Depressurize the line and valves as follows:
  - a. Open the valve and drain the line.
  - b. Close and open the valve to relieve any residual pressure that may be in the valve prior to removing the valve from service.
  - c. After removal and prior to any disassembly, drain any remaining media by placing the valve in a vertical position and carefully opening and closing the valve several times.
5. The practical and safe use of this product is determined by the trim, packing, seal rings and body ratings. Read the name tags and check the maximum temperature and rating listed. This product is available with a variety of trim materials. Some of the trim materials have pressure ratings that are less than the body ratings. All of the body and trim ratings are dependent on valve type and size, packing, seal rings, trim material, bolting material, and temperature. Do not exceed these ratings.

## TABLE OF CONTENTS

<b>Introduction</b> .....	3
General.....	3
Storage .....	3
Unpackaging .....	3
<b>Installation</b> .....	3
Final Check .....	3
<b>Disassembly</b> .....	4
Removal from Pipeline .....	4
Actuator Removal .....	4
<b>Valve Body Disassembly</b> .....	4
<b>Maintenance/Repair</b> .....	5
Lapping of Seats .....	5
Packing Box.....	5
Live-Loaded Packing Designs .....	6
Bellows Sealed Valves .....	6
<b>Valve Body Assembly</b> .....	6
Plug/Stem Assembly.....	6
Seat Ring Installation .....	7
Body Assembly V830 .....	7
Body Assembly V831 .....	7
<b>Actuator Mounting and Adjustment</b> .....	7
Actuator Mounting.....	7
Establishing Seat Load .....	8
<b>Important Notice</b> .....	8
Valve/Actuator/Travel.....	8
Actuator Bench Set and Span .....	8

## DIAGRAMS/TABLES

<b>Actuator Removal</b> (Fig. 1).....	4
<b>Bolt Tightening Sequence</b> (Fig. 2) .....	9
Table 1 .....	9
<b>Parts Identification V830</b> (Fig. 3) .....	10
Table 2 .....	10
<b>Parts Identification V831</b> (Fig. 4) .....	11
Table 3 .....	11
<b>V-Ring Single Set Packing</b> (Fig. 5) .....	12
<b>V-Ring Double Sets Packing</b> (Fig. 6) . . .	12
<b>Standard Square Packing</b> (Fig. 7).....	12
<b>Standard Grafoil Packing</b> (Fig.8) .....	12
Table 4 .....	12
<b>Live Loaded V-Ring Packing</b> (Fig. 9) . . .	13
<b>Live Loaded Grafoil Packing</b> (Fig. 10) . .	13
Table 5 .....	13

*These instructions provide information about safe handling and operation of the valve and are subject to change without notice.*

## INTRODUCTION

*The following instructions should be thoroughly reviewed and understood prior to installing, operating or performing maintenance on this equipment. Throughout the text, safety and/or caution notes will appear and must be strictly adhered to; otherwise, serious injury or equipment malfunction could result.*

A regularly scheduled training program is conducted to train customer service and instrumentation personnel in the operation, maintenance and application of control valves and instruments. Arrangements for these services can be made through your local representative. When performing maintenance, use only KOSO AMERICA replacement parts. Parts are obtainable through your local representative. When ordering parts, always include model and serial number of the unit being repaired. The model number, serial number, size and rating of the valve are shown on the identification tag located on the actuator.

### General

These installation and maintenance instructions apply to all sizes and ratings of the V830/V831 Series control valves regardless of the type of trim used. These instructions assume this valve has been supplied with a KOSO HAMMEL DAHL D/R Series pneumatic actuator. However, this valve is available with other types of actuators. When an actuator other than the D/R series has been provided, refer to the actuator manufacturer's literature for proper installation, maintenance and operation instructions.

### Storage

1. When a valve is to be stored for an extended period, remove the line connection covers and spray a light coating of machine oil on the internals. Replace the covers to prevent foreign matter from entering the valve body. Exposed parts should also be sprayed with a protective film of oil.
2. A packing list, containing a complete description of the valve and accessories (such as a valve positioner, etc.), accompanies each valve when shipped. This list should be checked soon after the shipment has been received.
3. When hoisting the valve, make sure that ropes or cables are of sufficient strength and are positioned so that any tubing or accessories will not be damaged.

### Unpackaging

Care must be exercised when unpacking the valve to prevent damage to the accessories and component parts. Should any problems arise, contact your local

representative.

## INSTALLATION

1. The best performance will be obtained if the valve is installed in a straight run of pipe away from elbows, restrictors or other areas where abnormal velocities may occur. The valve may be installed in any position; however, the vertical upright position is strongly recommended.
2. There should be at least one foot of clearance above the actuator in order to perform in line maintenance operations.
3. Care should be taken in rigging the valve for installation to assure that instruments or instrument lines are not damaged.
4. Before installing the valve in the line, clean the piping and the valve of all foreign material such as welding chips, scale, oil, grease or dirt. Gasket surfaces should be thoroughly cleaned to insure leak-proof joints.
5. Pipe threads should be clean and sharp. Apply pipe compound or joint sealer to the male threads only. Be sure that the compound or sealer is compatible with the process fluid.
6. The valve must be installed so that the controlled substance will flow through the valve in the direction indicated by the flow arrow located on the body.
- 7.(a)The V830 three-way valve is designed for blending flows. The valve connections are marked with the letters "C", "U", and "L" to indicate the COMMON, UPPER, and LOWER ports respectively. The COMMON port handles all the outlet flow; UPPER and LOWER ports each handle one of the incoming flows.
- 7.(b)The V831 three-way valve is designed for diverting (or splitting) flows. The valve connections are marked with the letters "C", "U", and "L" to indicate the COMMON, UPPER, and LOWER ports respectively. The COMMON port handles all the inlet flow. UPPER and LOWER ports each handle one of the diverting flows.
8. Where insulation of the valve body is required, DO NOT INSULATE THE VALVE BONNET.
9. An air supply pressure regulator with filter should be installed in the air line ahead of any valve mounted instruments. Factory mounted positioners are piped and adjusted at the factory.

### Final Check

1. Turn on the instrument air supply and set pressure 5 psig greater than required by the bench set listed on the label plate.
2. Check the air lines to the actuator for leaks.
3. Vary the air supply to the actuator to ascertain that the actual valve travel (stroke) corresponds with the data in Table 1.

4. Check to be sure that the combined actions (direct and reverse) of the controller, positioner, etc. and valve, produce desired direction of movement, and will ensure the required valve position in the event of air supply failure.

**NOTE:** Under actual operating conditions the pressure drop across the valve may differ from the calculated figures. Some actuators may require readjustment of the spring preload in order to provide adequate shutoff force. In this situation check to ensure that the actuator is still capable of full valve travel with the available supply air pressure.

5. Tighten the packing flange stud nuts evenly to assure optimum sealing pressure on the stem and packing box walls. In most cases, packing flange stud nuts should be slightly more than finger tight to provide adequate sealing and prevent packing box leakage. Refer to Packing Box instructions for additional information. Over tightening will restrict stem movement and adversely affect the process control.

## DISASSEMBLY

Read these instructions completely. For your safety, it is important that the following precautions be taken prior to removal of the unit from the line or before any disassembly.

1. Wear any protective equipment normally required when working with the fluid involved during removal and disassembly.
2. Depressurize and drain the pipeline with the valve open prior to disconnecting service lines.
3. Before removing the instrument connections from the actuator, shut off the air pressure and bleed the air lines.
4. Have adequate rigging transport means available at the valve before attempting to remove it from the pipeline or before breaking the body/bonnet joint for in-line service.

## Removal from Pipeline

**NOTE:** Maintenance such as diaphragm and packing replacement can be done without removing the valve from the line.

1. Disconnect all instrument air and electrical lines from the actuator.
2. Remove all inlet and outlet line flange studs and nuts and lift the valve out of the pipeline.
3. Secure the valve and actuator assembly firmly on a work bench in an upright position in a manner to prevent tipping or falling over.

## Actuator Removal

1. Connect instrument air to the actuator and

apply signal pressure sufficient to move the plug to a position only slightly off the seat. This will remove the spring force from the coupling before disassembly.

2. Disconnect the actuator coupling from the valve stem by disengaging the coupling screws (Figure 1). Disconnect air supply.
3. Unscrew the clamp nut from the bonnet by placing a metal rod or blunt nosed chisel on the clamp nut lugs and striking with a mallet.
4. Unscrew the clamp nut from the threads and lift the nut over the plug stem.
5. Lift or hoist the actuator unit off the valve, taking care to avoid damaging the plug stem, instruments or tubing.
 

**NOTE:** The actuator is removed from the body as a unit, without disturbing the packing box bolt-bolting. Clamp nut and actuator yoke will pass over the packing flange.
6. If maintenance is required on the actuator consult the appropriate actuator IMO.

## VALVE BODY DISASSEMBLY

1. Unscrew the packing flange nuts and remove packing flange and packing follower.
2. Remove the bonnet/body stud nuts.

After disassembling the bonnet, the body assembly should be inverted.

3. Remove the cage and discard the lower body gasket.
4. Remove the valve plug and stem assembly from the body.
  - a. If plug or stem is to be remachined or replaced, drive out the plug stem pin and unscrew the stem.
5. Unscrew and remove the seat ring from the body and seat ring from the cage.

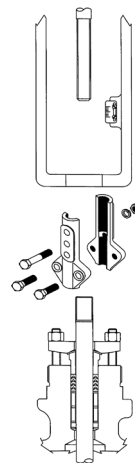

FIGURE 1 Actuator Removal

6. Remove the seat rings from the body—upper seat ring through the top of the body, lower through the bottom of the body.

**NOTE:** Seat rings should be removed only for remachining or replacement. They should not be removed for cleaning purposes. Special Hammel-Dahl wrenches are available for seat removal. A lathe or boring mill can be used for unscrewing seat rings. Heating the valve body or chilling the seat rings may be required to loosening extremely tight seats. The guide bushing should be removed from bonnet only for replacement. A stud welded into the guide can serve as a jackscrew puller.

## MAINTENANCE/REPAIR

The purpose of this section is to assist maintenance personnel by suggesting methods of component maintenance which may be largely dependent on the tools and machine shop equipment available. Each section should be read and understood before proceeding.

### Lapping of Metal Seats

Lapping is the process of working the valve plug against the seat ring with an abrasive to produce a close fit. When valve leakage becomes excessive, lapping becomes necessary. The plug and seat ring seating surfaces should be free of large scratches or dents, and the contact surfaces of the seats should be as narrow as possible. Lapping can correct shallow scratches or slight roughness only. Excessive lapping produces a groove in the plug, therefore plugs or seats having relatively deep scratches must be re-machined.

1. Place the seat ring into the valve body.

**CAUTION:** These instructions are intended for non-bellows sealed valves only. Twisting of a bellows sealed stem will cause damage to the bellows seal. To lap bellows sealed valves, the seat must be removed from the valve and hand lapped to the plug.

2. Lapping compound should be grade "A" or finer. The compound should be mixed with a small quantity of lubricant such as graphite. This will slow the cutting rate and prevent tearing of the seat surfaces.
3. Apply lapping compound to the seating surface of the seat ring only.
4. A film of light machine oil on the valve plug stem will facilitate stem movement during the lapping procedure.

**NOTE:** A "T" handle for the valve plug stem can be made by welding a nut (with threading to match the plug stem threads) to the center of a rod.

5. Lap with short, oscillating strokes. The weight of

the plug, stem, and lapping tool provides ample pressure for lapping do not bear down.

6. Raise the plug occasionally, lower it to another position and resume the oscillating strokes. This ensures an even lap over the entire seating surfaces of plug and seat.
7. Approximately 5 to 10 minutes lapping time, with grade A compound, is usually required to obtain a satisfactory fit between a new plug and seat.
8. Clean the plug and seat, then, holding the plug on the seat by hand, apply compressed air to the inlet side of the valve to check the tightness of the lapped parts. Repeat the lapping procedure if necessary.
9. Disassemble the valve and clean all parts thoroughly. Remove all traces of lapping compound. Remove the temporary packing and clean the packing box.

### Packing Box

Packing box maintenance is one of the principle chores of routine servicing. Tightness of the packing is maintained by packing compression. Compression is achieved by evenly tightening the packing flange nuts against the packing flange. Care must be taken not to over tighten, as this could prevent smooth operation of the valve. If all compression is used up and the valve leaks, new packing is required.

In live-loaded packing, the compression is provided by the Belleville spring washers. Proper adjustment of the spring washers is required to achieve and maintain packing tightness.

Packing box maintenance may be performed as a part of major disassembly and repair or as a separate routine with the valve installed in the process line. In either case the following steps should be closely adhered to, otherwise serious injury or equipment damage could result.

**CAUTION:** Valve must be isolated, and the pressure vented before performing packing box maintenance.

1. Loosen and remove packing flange nuts.
2. Raise packing flange and packing follower up the valve stem.

**NOTE:** If the new packing rings are solid endless rings (i.e.: TFE V-ring, grafoil, etc.), the actuator stem coupling will have to be disconnected. Refer to the actuator removal section of these instructions for details of coupling removal. If the coupling is to be removed, the packing box flange and follower can be removed completely.

3. Using a narrow hook or bent wire, pull the old packing rings and lantern ring or spring out of the packing box.

**CAUTION: When removing packing rings from the packing box, use a hook, bent wire or tool which is softer than the bonnet material to prevent scratching or marring of the packing box surfaces.**

4. Replace packing referring to Figures 5 8 for correct amount of packing and the correct sequence of installation.

**NOTE:** *A thin film of silicone lubricant will ease assembly.*

**CAUTION: Avoid damage to packing ring when slipping them over the stem threads.**

5. Slide the packing follower over the stem.
6. Place the packing flange, flat side up, over the stem and flange studs to rest on the packing follower.
7. Screw the packing flange nuts onto the studs and tighten them evenly to avoid cocking the flange.

**NOTE:** *Finger tightening of the packing flange nuts should provide ample sealing pressure to the packing rings. When the valve is placed in service this adjustment should be checked, and the nuts tightened just enough to prevent any leakage. Excessive tightening will bind the valve stem and prevent sensitive response.*

8. In some applications, packing boxes are designed for use with a lubricator. The lubricator is provided with a ball check valve to prevent back flow of the process fluid. On some valves, an isolating valve is added for positive protection against back flow. The lubricator should be kept filled with the specified lubricant and turned in firmly but not tightly. One or two turns of the lubricator, once every two weeks should suffice to provide the desired seal.

## Live-Loaded Packing Designs

1. Loosen and remove packing flange nuts.
2. Raise packing flange, packing follower and spring washers up the valve stem.

**Note:** *If the new packing rings are solid endless rings (i.e., TFE V-ring, grafoil, etc.), the actuator stem coupling will have to be disconnected. Refer to the actuator removal section of these instructions for details of coupling removal. If the coupling is to be removed, the packing box flange, follower and springs can be removed completely.*

3. Using a narrow hook or bent wire, pull the old packing rings and lantern ring or spring out of the packing box.

**Caution: When removing packing rings from the packing box, use a hook, bent wire or tool which is softer than the bonnet material to prevent scratching or**

**marring of the packing box surfaces.**

4. Replace packing referring to Figures 9 or 10 for correct amount of packing and the correct sequence of installation.

**Note:** *A thin film of silicone lubricant will ease assembly.*

**Caution: Avoid damage to packing ring when slipping them over the stem threads.**

5. Replace DU bearing in the packing follower and slide over the stem.
6. Replace the spring washers in the proper orientation (refer to figures 9 and 10) for the packing material.
7. Place the packing flange over the stem and flange studs to rest on the packing follower.
8. Screw the packing flange nuts onto the studs and tighten them evenly to void cocking the flange.

**Note:** *Packing flange stud nuts should be tightened until the scribed line on the packing follower becomes visible above the packing flange.*

## Bellows Sealed Valves

**CAUTION: One end of the bellows is welded to the stem while the other end is welded to the flange. Any twisting of these two parts will result in damage to the bellows**

1. Disassembly of a bellows sealed valve follows the same procedure as Valve Body Disassembly on page 4.
2. Damaged bellows assemblies are replaced as a complete unit.
3. If plug removal becomes necessary, carefully inspect the portion of the plug shank that can be seen below the guide bushing. If the pin cannot be seen, the bellows assembly must be held in a vice and the stem moved downward slightly until the pinned connection is visible.

**CAUTION: In the relaxed condition the bellows will be at mid travel. The stem may be moved downward 1/2 of the valve travel listed in Table 1.**

4. If lapping of the plug and seat ring is required, the seat ring must be removed from the body and hand lapped to the plug/bellows assembly.
5. Reassembly of a bellows sealed valve follows the same procedure as Valve Body Assembly.

## VALVE BODY ASSEMBLY

After completion of the required maintenance the valve should be reassembled using the following procedures:

## Plug/Stem Assembly

1. Screw the stem solidly into the plug.
2. Place the plug shank on a v-block and using a suitable size drill-bit, drill the stem using the hole in the plug as a guide.
3. Remove any burrs from the plug guide by making a slight counterbore.
4. Select the correct size pin, apply a small amount of grease on it and press into the hole.

**NOTE:** The pin must be recessed approximately 1/16" below the plug guide surface.

5. After the plug has been pinned, it should be placed in a lathe to insure it is running "true." If it is not, strike the plug with a soft faced mallet to straighten.

## Seat Ring Installation

1. Apply a small amount of sealant to the seat ring threads and sealing shoulder and install.
2. Using a seat ring wrench fabricated for removal, tighten the seat ring only enough to insure a seal.

**Caution: Do not over tighten. Do not strike seat ring lugs; this could distort the seat ring resulting in unwarranted seat leakage.**

## Body Assembly—V830

1. Screw the seat ring (upper) tightly into the body, and the seat ring (lower) into the cage—then clean up the excess compound.

**NOTE:** Hammel Dahl wrenches are available for tightening seat rings. If plug and/or seat has been remachined or replaced, the members must be lapped together.

2. Lower the plug and stem assembly into the body while carefully guiding the plug into the seat ring.
3. Place a new gasket on the body and lower the cage carefully over the plug and body studs to its place on the body.
4. Install the stud nuts and tighten them evenly.
5. Turn the body upright.

**NOTE:** Hold the plug stem to prevent the plug from dropping onto the lower seat ring.

6. If the guide bushing has been removed, press a new bushing into the bonnet.
7. Place a new bonnet gasket on the body and lower the bonnet carefully over the plug stem to its place on the body.
8. Bolt the bonnet evenly and securely to the body.
9. Install new packing.

## Body Assembly—V831

1. Screw the seat ring (upper) tightly into the body, and the seat ring (lower) into the cage—then clean up the excess compound.

**NOTE:** Hammel Dahl wrenches are available for tightening seat rings. If plug and/or seat has been remachined or replaced, the members must be lapped together. See Lapping Instructions.

2. Lower the plug and stem assembly into the body while carefully guiding the plug into the seat ring.
3. If the guide bushing has been removed, press a new bushing into the bonnet.
4. Place a new bonnet gasket on the body and lower the bonnet carefully over the plug stem to its place on the body.
5. Bolt the bonnet evenly and securely to the body.
6. Install new packing.
7. Install the lower valve plug head as follows:

- a. Invert the body and hold the stem upward (plug against its seat), then place the gasket on the end of the plug.
- b. Carefully slip the plug head over the plug threads.
- c. Add lock washer and lock nut.
- d. Place a new gasket on the body and lower the cage carefully over the plug and body studs to its place on the body.

## ACTUATOR MOUNTING AND ADJUSTMENT

The following instructions are for the traditional D/R series spring/diaphragm actuator. Instructions for other actuators can be obtained from your local representative.

### Actuator Mounting

1. Lower the actuator over the plug stem and packing flange to seat squarely on the bonnet shoulder.
2. Rotate the actuator to a convenient position, then screw the clamp nut onto the valve bonnet threads and tighten it securely.
3. Connect a regulated air supply to the actuator diaphragm connection. The supply should be at least 5 psig greater than the pressure needed to stroke the actuator.
4. The actuator must be in the down position.

**NOTE:** For "R" series actuators, the spring will maintain the actuator on the down travel stop and no air pressure is required. For "D" series actuators, regulate the supply pressure to the actuator to move the actuator stem downward until the downward motion is the same as

the travel listed in Table 1 plus 1/8 inch.

5. The valve plug must be on its seat while the actuator stem is being connected.
6. Press half of the actuator coupling against the actuator stem and valve plug stem so that each stem is engaged in the coupling half at least one stem diameter.

**NOTE:** It may be necessary to move the valve plug off its seat a slight distance in order to mesh the valve plug stem threads with the coupling threads.

7. Apply the other half of the coupling, carefully engaging threads, then insert the coupling cap screw and tighten it by hand (Refer to Figure 1).

## Establishing Seat Load

1. Maintain the actuator stem at its lowest position of travel.
2. If the plug moved off the seat during the stem connection procedure, prevent the stem coupling from rotating, and unscrew the valve plug stem out of the coupling until the plug is seated.

**CAUTION: Unscrew the plug stem until the seat is contacted. Do not continue to unscrew. Rotating the valve plug while in contact with the seat ring can cause destruction of the seat and galling.**

3. Move the plug off the seat by adding air supply to the "R" series actuator or decreasing air supply to the "D" series actuator. Unscrew the valve plug stem an additional one-half turn out of the actuator coupling to ensure positive seating.
4. Tighten the connector cap screws securely.
5. Seat the valve plug firmly by means of the actuator.

## IMPORTANT NOTICE

If these steps have been performed correctly the valve plug is on the seat ring, the actuator has been raised upward off its down travel stop, the actuator thrust is applied to the valve trim, and valve leakage will be within acceptable limits. If maintenance work has been performed and seat leakage is exceptionally high, these steps should be repeated in order to ensure that adequate seat load has been established.

## Valve/Actuator/Travel

1. Adjust the travel indicator scale on the actuator yoke leg so that the "Shut" mark is opposite the travel indicator on the actuator stem coupling.
2. Stroke the valve/actuator combination by regulating the air supply to the diaphragm case. Note the travel on the indicator scale.
3. The actual travel should agree with the travels listed in Table 1.

**NOTE:** If the actual travel is less than the travel listed in Table 1, the actuator coupling should be removed and the steps in the previous sections repeated.

## Actuator Bench Set and Span

1. The actuator bench set (spring preload) is stamped on the actuator identification tag located on the actuator leg.
  2. Using a regulated air supply with a gage connected between the regulator and the diaphragm case, stroke the valve actuator combination.
  3. Record the actuator air pressure at the actuator full up and full down position. This is the bench set and should agree with the bench set stamped on the identification tag.
  4. If the actual bench set does not agree with the identification tag, the bench set can be adjusted by rotating the actuator spring adjuster.
  5. The actuator spring span is the arithmetic difference between the bench set upper limit and lower limit.
-



Model V830/V831

TABLE 1							
Valve Size	Press Class	Valve Travel	Stud Size	Qty.	Req'd Torque lb-ft		Torque Sequence
					B7	B8M, CL2	
1 1/2"	Up to 600 CL.	1.12"	1/2 13	8	50 60	50 60	SEQ. 8
2"	Up to 600 CL.	1.12"	1/2 13	8	50 60	50 60	SEQ. 8
3"	Up to 600 CL.	1.50"	1/2 13	8	50 60	50 60	SEQ. 8
4"	Up to 600 CL.	1.50"	1/2 13	8	80 90	80 90	SEQ. 8
6"	Up to 600 CL.	2.25"	5/8 11	12	125 150	125 150	SEQ. 12
8"	Up to 600 CL.	2.25"	5/8 11	16	80 90	80 90	SEQ. 16

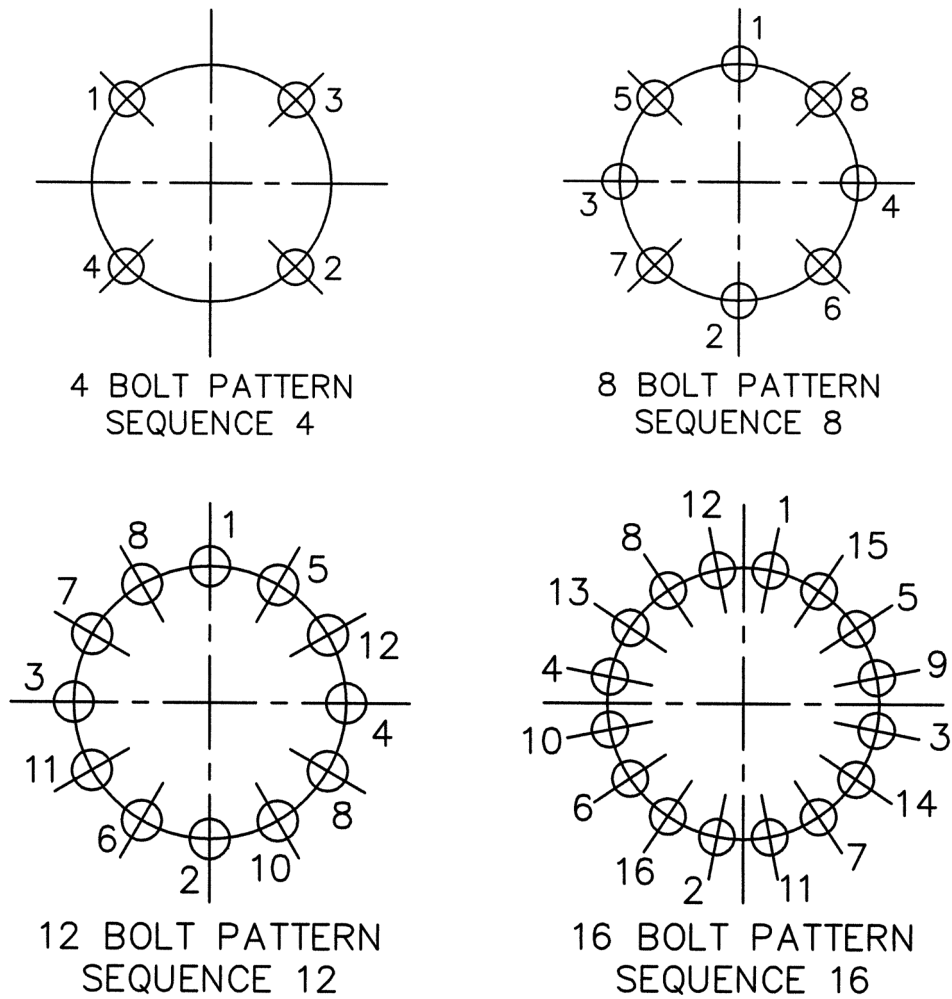
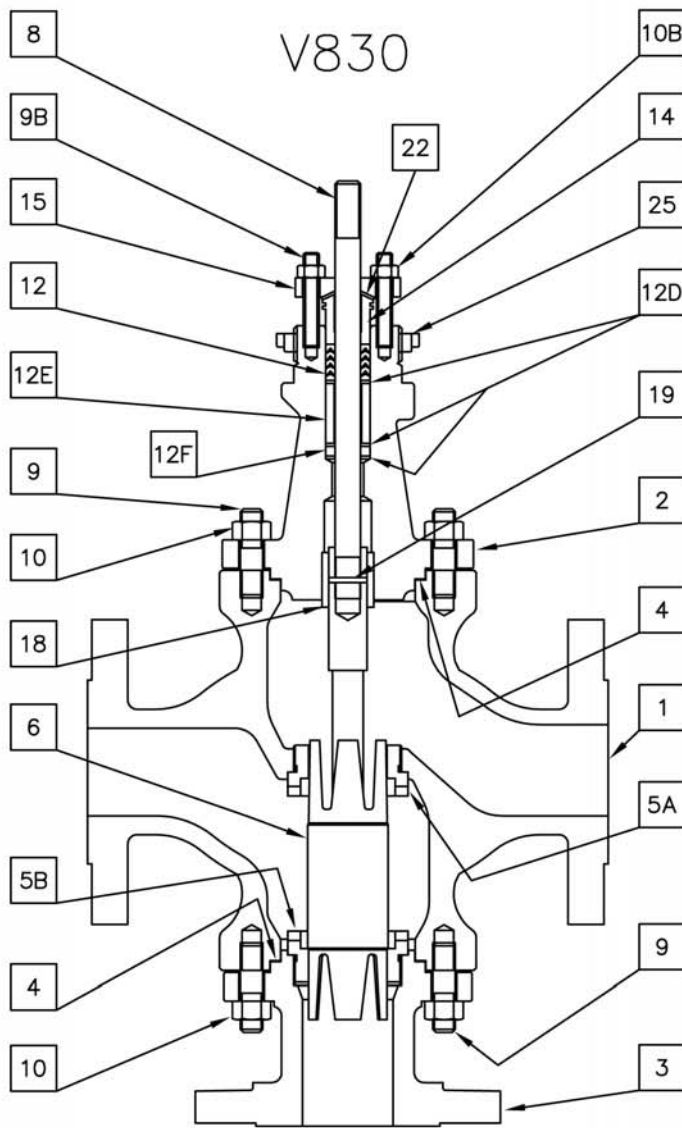

FIGURE 2 Bolt Tightening Sequence

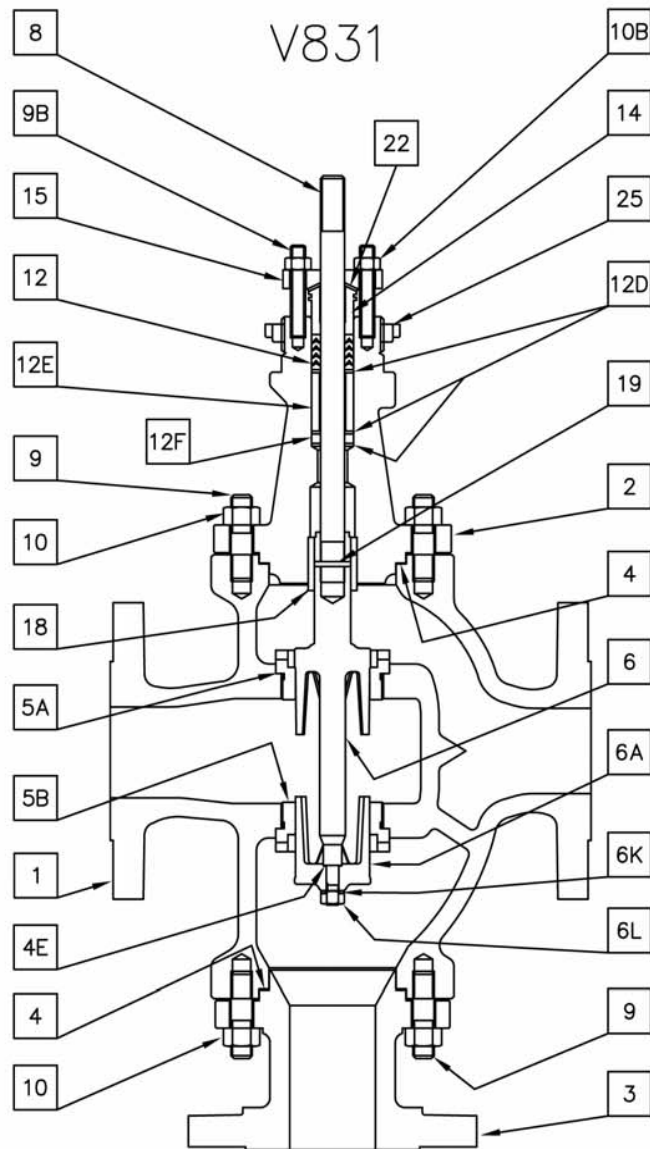

**FIGURE 3 V830 Parts Identification**

3/4" – 10" SERIES V830  
ANSI CLASS 150,300,600  
3 WAY GLOBE

**TABLE 2 V830 Parts List**

ITEM	DESCRIPTION	ITEM	DESCRIPTION	ITEM	DESCRIPTION
1	BODY	9	BODY STUD	14	PACKING FOLLOWER
2	BONNET	9B	PACKING STUD	15	PACKING FLANGE
3	BOTTOM FLANGE	10	BODY STUD NUT	18	GUIDE BUSHING
4*	BONNET GASKET	10B	PACKING STUD NUT	19*	PIN
5A*	UPPER SEAT RING	12*	PACKING	22	FELT WIPER
5B*	LOWER SEAT RING	12D	WASHER	25	CLAMP NUT
6*	PLUG	12E	PACKING SPACER		
8*	STEM	12F	WIPER RING		
* RECOMMENDED SPARE PARTS.					

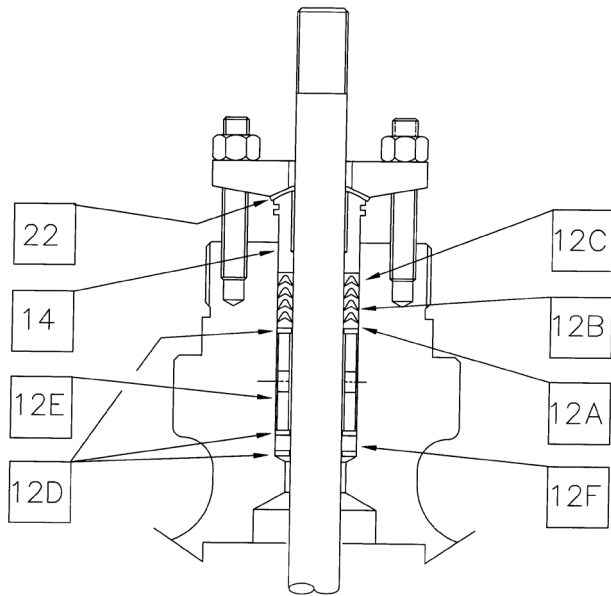

**FIGURE 4 V831 Parts Identification**

1 1/2" - 10" SERIES V831  
ANSI CLASS 150,300,600  
3 WAY GLOBE

**TABLE 3 V831 Parts List**

ITEM	DESCRIPTION	ITEM	DESCRIPTION	ITEM	DESCRIPTION
1	BODY	6K*	PLUG LOCKWASHER	12E	PACKING SPACER
2	BONNET	6L*	PLUG NUT	12F	WIPER RING
3	BOTTOM FLANGE	8*	STEM	14	PACKING FOLLOWER
4*	BONNET GASKET	9	BODY STUD	15	PACKING FLANGE
4E*	VALVE PLUG GASKET	9B	PACKING STUD	18	GUIDE BUSHING
5A*	UPPER SEAT RING	10	BODY STUD NUT	19*	PIN
5B*	LOWER SEAT RING	10B	PACKING STUD NUT	22	FELT WIPER
6*	VALVE PLUG	12*	PACKING	25	CLAMP NUT
6A*	VALVE PLUG BODY	12D	WASHER		
* RECOMMENDED SPARE PARTS.					



**TFE V-Ring  
Single Set Packing  
FIGURE 5**

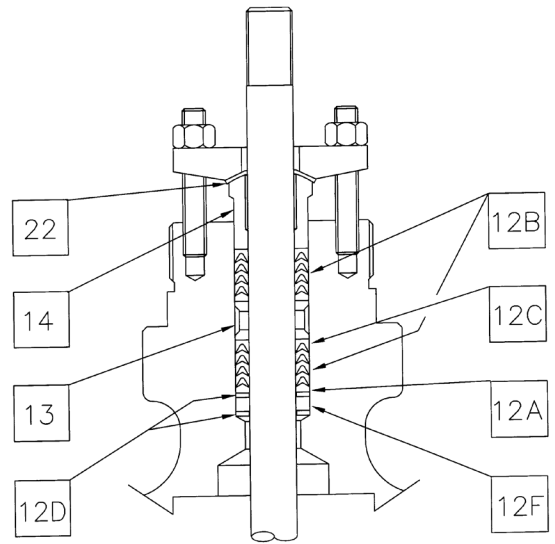

**TFE V-Ring  
Double Sets Packing  
FIGURE 6**

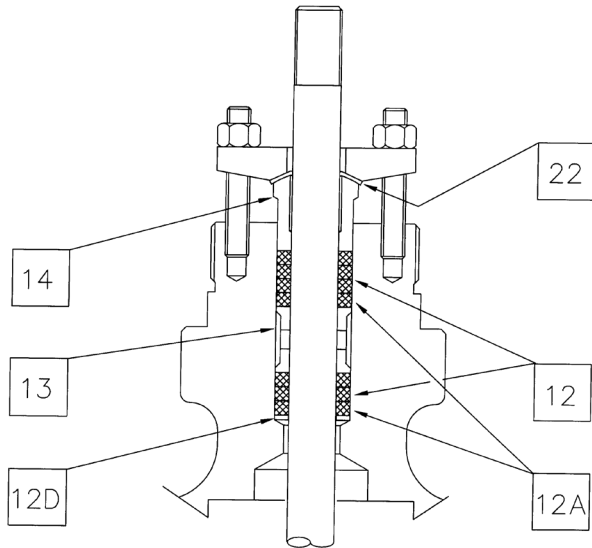

**Square Packing  
FIGURE 7**

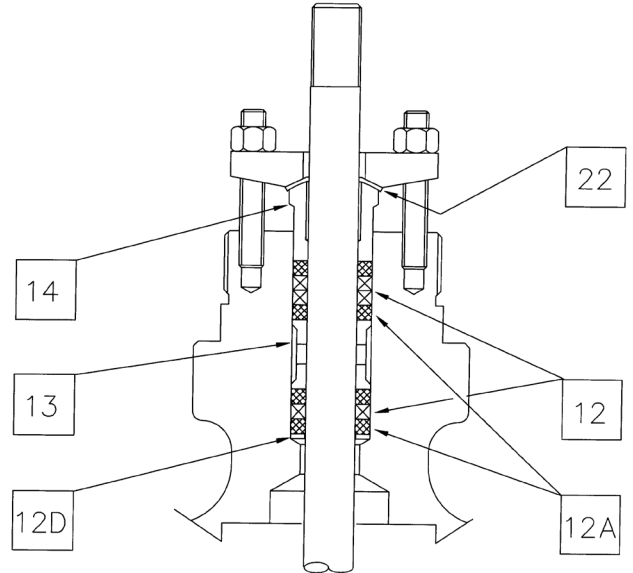

**Grafoil/Graphite  
Standard Grafoil Packing  
FIGURE 8**

TABLE 4				
Packing Sub-Assembly Parts List				
ITEM	DESCRIPTION		ITEM	DESCRIPTION
12*	Packing Set		12F*	Wiper Ring
12A*	Male Adapter		12G*	Packing Ring
12B*	V-Rings		13	Lantern Ring
12C*	Female Adapter		14	Packing Follower
12D	Packing Washer		22*	Felt Wiper
12E	Packing Spacer			
*Recommended Spare Parts				

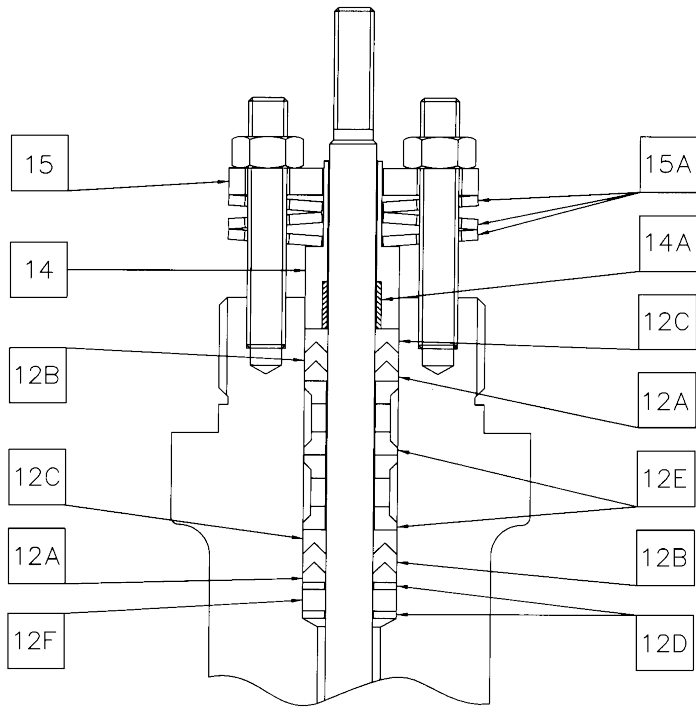

**Live Loaded  
PTFE V-Ring  
Packing**

**Live Loaded  
Grafoil  
Packing**

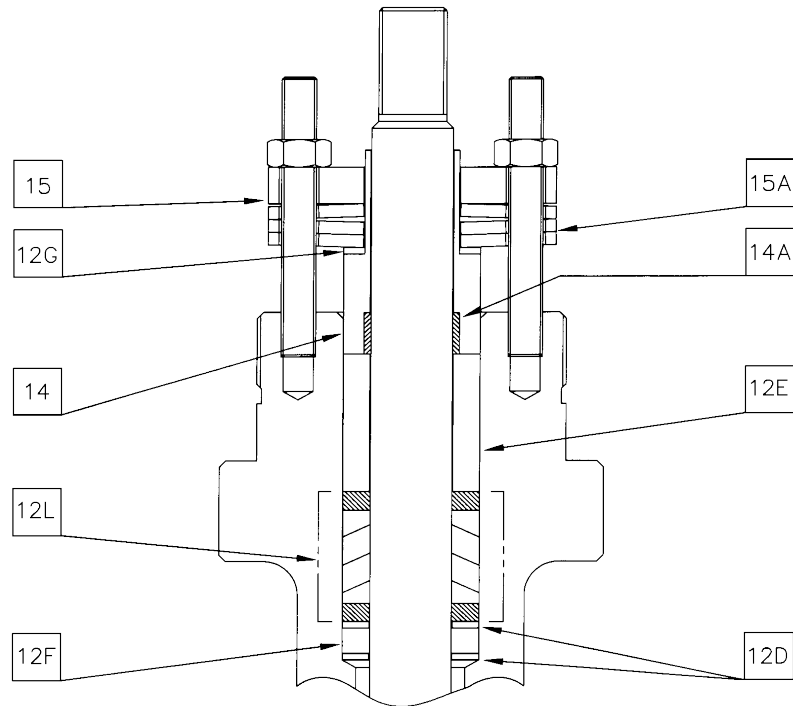

TABLE 5				
Packing Sub-Assembly Parts List				
ITEM	DESCRIPTION		ITEM	DESCRIPTION
12*	Packing		12G*	Packing Ring
12A*	Male Adapter		12L*	Packing Set
12B*	V-Rings		13	Lantern Ring
12C*	Female Adapter		14	Packing Follower
12D	Packing Washer		14A	DU Bearing
12E	Packing Spacer		15	Packing Flange
12F*	Wiper Ring		15A	Spring Washers
*Recommended Spare Parts				



**KOSO HAMMEL DAHL** CONTROL VALVES

**KOSO VECTOR kentintrol™**

KOSO HAMMEL DAHL  
253 Pleasant Street  
W. Bridgewater MA 02379

Telephone: 774.517.5300  
[www.hammeldahl.com](http://www.hammeldahl.com)

**REX**  
ELECTRAULIC™ ACTUATION

**PARCOL**