

KOSO HAMMEL DAHL

CONTROL VALVES

KOSO HAMMEL DAHL

253 Pleasant Street
West Bridgewater, MA 02379

tel: 774.517.5300
www.hammeldahl.com

Installation, Maintenance & Operating Instructions

IMO – Positioner Mounting

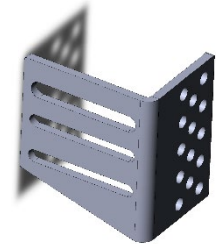

Read these instructions carefully before installation or servicing.

WARNING!

FOR YOUR SAFETY AND PROTECTION, IT IS IMPORTANT THAT THE FOLLOWING PRECAUTIONS BE TAKEN PRIOR TO REMOVING THE VALVE FROM SERVICE OR BEFORE ANY DISASSEMBLY OF THE VALVE:

1. DO NOT place your hand in the valve port at any time when the units are assembled. A remotely actuated valve could close at any time and result in serious injury.
2. Know what media is in the line. If there is any doubt, check with the proper authority.
3. Wear any protective clothing or equipment normally required when working with the fluid involved during removal and disassembly
4. Shut off the service pressure and bleed the service lines before removing the service line connectors from the actuator.
5. If the valve/actuator assembly is removed from the line as a unit, make sure both upstream and downstream sides of the line are depressurized before removal. Refer to valve IMO for more instructions.
6. Ensure that the spring is decompressed before disassembly.

Contents

GENERAL INSTRUMENTATION MOUNTING GUIDELINES	3
Globe Valve Orientation	3
Actuator Orientation	3
Positioner Mounting to a Spring and Diaphragm Actuators.....	3
Tubing.....	3
Figure 1: Front view of mounting bracket (representation using a A46/A47 actuator with a positioner for reference).....	4
Figure 2: Side view of mounting bracket (representation using a A46/A47 actuator with a positioner for reference).....	4
Figure 3: Representation Parts Identification for mounting bracket for Neles NE/NP Positioner - D/R actuator	4
Figure 4: Representation Parts Identification for mounting bracket for Neles ND, Siemens 760P and PS2 positioner - D/R actuator	5
Figure 5: Representation Parts Identification for mounting bracket for D52B/C - R52B/C Actuators	6
Figure 6: Representation Parts Identification for mounting bracket for D52D - R52D Actuators	6

These instructions provide information about safe handling and operation of the valve and are subject to change without notice.

GENERAL INSTRUMENTATION MOUNTING GUIDELINES

Note: Specific customer instructions may supersede these general guidelines; please consult the factory order or your supervisor for specific instructions.

This IMO is to be used in conjunction with the valve, actuator, and positioner IMO.

Globe Valve Orientation

As the standard of default orientability view the valve such that the piping flow direction is from left to right. The valve inlet will now be on the left side and the valve outlet will be on the right side. The side of the valve you are looking at is the Front of the valve. View the valve such that the piping flow direction is from right to left. The valve inlet will now be on the right side, and the valve outlet will be on the left side. The side of the valve you are looking at is the Back of the valve.

Actuator Orientation

When looking at the side of the valve, the stroke scale mounting tab of the cast actuator yoke will standardly be located at the right side of the valve, and the slot in the actuator leg will be located on the left side.

Actuator side mounted handwheels will be mounted on the back side of the actuator yoke.

The actuator air supply is to be set at 5 psig above the upper spring range of the actuator.

Positioner Mounting to a Spring and Diaphragm Actuators

The positioner will standardly be mounted on the Front side of the valve and positioned to the left of the actuator center line. The distance the positioner is placed left of the actuator center line is determined by the valve stroke

The positioner filter air regulator will be close nipple mounted to the positioner and are bracketed to the back side of the actuator and piped into the positioner. Solenoid valves, depending on size and space, will either be nipple mounted or bracket mounted to the yoke of the actuator. Stem Connector Pin Length may require trimming to desired length as to engage in the lever arm while not contacting the back of the positioner.

Limit switches will be bracket mounted to the actuator yoke and located on the back side of the valve and to the right of the actuator center line while looking at the

front side of the valve.

Refer to actuator Bill of Materials for complete list and quantities of parts. For an overview Bill of Materials, reference Tables and Figures on pages 4 and 5.

Tubing

Standard tubing will be stainless steel with compression fit type fittings. All tubing will be piped as close to the actuator spring barrel as possible. Metal tubing will have at least two right hand bends from connector to connector to allow for flexibility. Copper tube or rubber house may be specified when required.

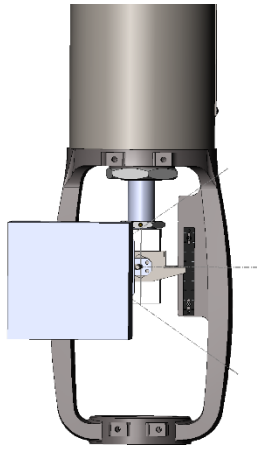

Figure 1: Front view of mounting bracket (representation using a A46/A47 actuator with a positioner for reference)

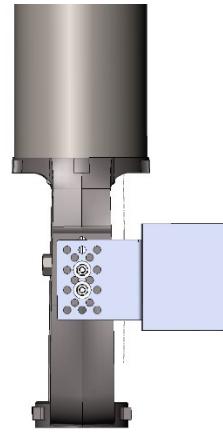

Figure 2: Side view of mounting bracket (representation using a A46/A47 actuator with a positioner for reference)

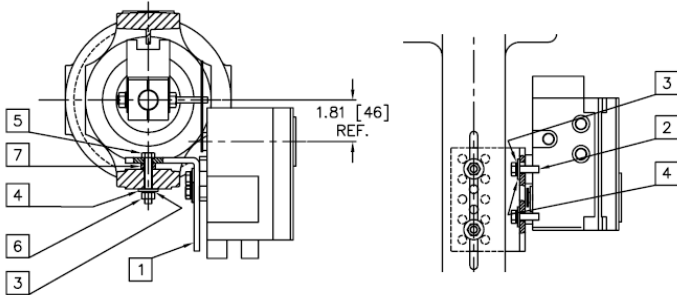

Figure 3: Representation Parts Identification for mounting bracket for Neles NE/NP Positioner - D/R actuator

* Note that the bracket for the D/R is shown mounting to the inside of the yoke. This is applicable to valves 6 -inch and under. Valves that are 8-inch an over, the bracket is mounted to the outside of the yoke.

Table 1: General Bill of Material – D/R mounting bracket for Neles NE/NP positioner

Part No.	Part Name
1	Mounting Bracket
2	Screw
3	Split Lock Washer
4	Flat Washer
5	Screw
6	Hex Nut
7	Tube Spacer *
* Only for 140 and 240 Sq. In. actuators	

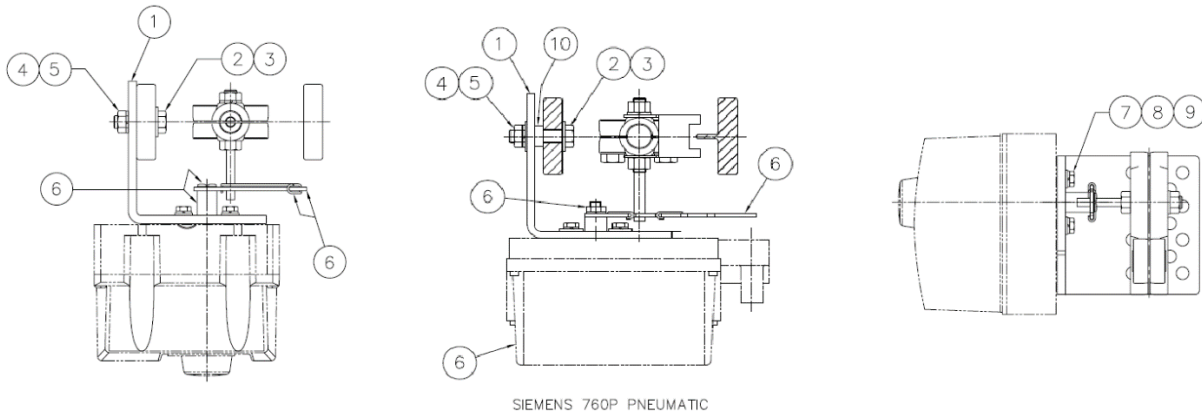

Figure 4: Representation Parts Identification for mounting bracket for Neles ND, Siemens 760P and PS2 positioner - D/R actuator

Table 2: General Bill of Material – D/R mounting bracket for Neles NE/NP positioner

Part No.	Part Name
1	Mounting Bracket
2	Screw
3	Flat washer
4	Split Lock Washer
5	Hex Nut

Part No.	Part Name
6	Positioner Arm Kit
7	Screw
8	Flat washer
9	Split Lock Washer
10	Spacer *
* For Siemens 760P positioner	

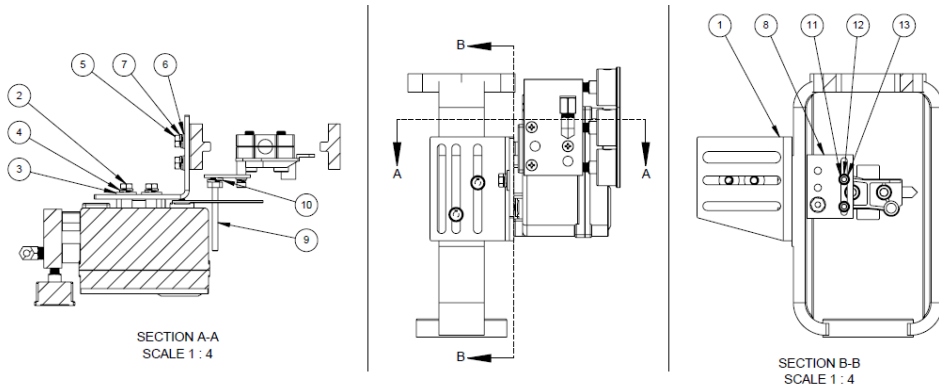

Figure 5: Representation Parts Identification for mounting bracket for D52B/C - R52B/C Actuators

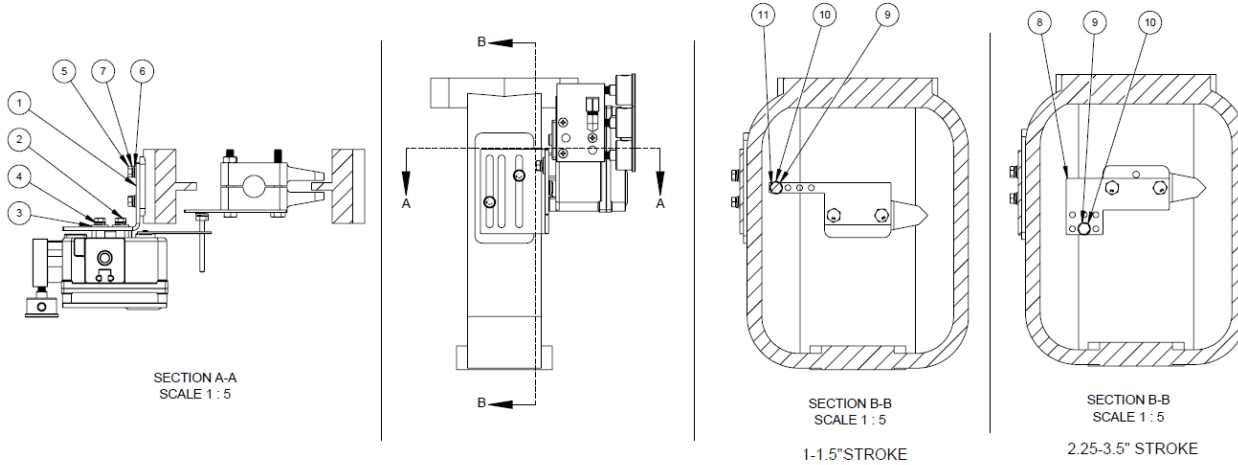

Figure 6: Representation Parts Identification for mounting bracket for D52D - R52D Actuators

Table 3: General Bill of Material – D52/R52 mounting bracket

Part No.	Part Name
1	Positioner Bracket
2	Screw
3	Flat Washer
4	Split Lock Washer
5	Screw
6	Flat Washer
7	Split Lock Washer

Part No.	Part Name
8	Pin Bracket
9	Stem Connector Pin
10	Split Lock Washer
11	Screw *
12	Flat Washer *
13	Split Lock Washer *
* For D52B/C and D/52 B/C only	

KOSO HAMMEL DAHL
 253 Pleasant Street
 W. Bridgewater MA 02379

Telephone: 774.517.5300
 Fax: 774.517.5230
www.hammeldahl.com

CONTROL VALVES
KOSO HAMMEL DAHL



KOSO HAMMEL DAHL CONTROL VALVES

KOSO HAMMEL DAHL
253 Pleasant Street
W. Bridgewater MA 02379

Telephone: 774.517.5300
www.hammeldahl.com

KOSO VECTOR **kentintrol**[™]

REX
ELECTRAULIC[™] ACTUATION

PARCOL